



TC-142 & TC-1421 TRANSFER CASE

SERVICE MANUAL

TABLE OF CONTENTS

	SECTION
<u>TC-142 TRANSFER CASE SERVICE MANUAL</u>	1.0
Introduction	1.1
Specification	1.2
Assembly Views.....	1.3
<u>LUBRICATION</u>	2.0
Recommended Lubricants.....	2.1
Off-Highway and Mining Equipment.....	2.2
Inspection	2.3
Oil Change	2.4
Draining the Oil	2.5
Refilling the Oil.....	2.6
Operating Temperature.....	2.7
<u>CLEANING & INSPECTION</u>	3.0
Cleaning	3.1
Drying & Corrosion Inhibition	3.2
<u>GENERAL INSTRUCTIONS</u>	4.0
Safety	4.1
Assembly Precautions.....	4.2
Removal & Installation.....	4.3
<u>DISASSEMBLY</u>	5.0
General Disassembly.....	5.1
Declutches	5.2
<u>ASSEMBLY</u>	6.0
Intermediate Shaft	6.1
Upper Shaft.....	6.2
Lower Shaft Sub-Assembly.....	6.3
Lower Shaft Installation	6.4
Bearing Adjustment.....	6.5
Shift Shaft.....	6.6
Declutches	6.7
Pump & Plumbing	6.8
<u>TORQUE SPECIFICATIONS</u>	7.0
<u>ILLUSTRATED PARTS</u>	8.0
<u>PARTS LIST</u>	9.0
<u>TOOLS</u>	10.0

1.0 TC-142 TRANSFER CASE

1.1 INTRODUCTION

The Fabco TC-142 two-speed transfer case is a family of units designed for use in all wheel drive vehicles. The TC-1421 is a single-speed version of the same case. They provide drive to the front axles and can be used in any configuration of driven axles. The front drive axle can be engaged at any vehicle speed, provided the rear wheels are not spinning; however, the vehicle must be stationary before the shift can be made between the high and low ranges, otherwise serious damage may occur. The shifting between ranges and the engagement of front drive and power take-off clutches is accomplished by air operated cylinders. A lubrication pump is standard on all models, and may be used for oil circulation should an oil cooler installation be deemed necessary.

Two proportioning differentials are optionally available on these transfer cases, one provides 50 percent of the driving torque to the front axle and 50 percent to the rear. This is designated as a 50/50 differential. The other proportioning differential provides 26% to front and 74% to the rear axle (26/74). Proportioning differentials provide drive torque to both front and rear axles at all times that the wheels have traction. Should one axle start to slip, the differential must be "locked out" to provide positive drive to all axles. The servicing of the proportioning differentials is covered in supplementary literature. A power take-off or direct mounted hydraulic pump drive, optionally mounted on the rear of the input shaft, is capable of transmitting full engine horsepower.

1.2 SPECIFICATIONS

The TC-142 transfer case is a two-speed, 3 shaft constant mesh design with air operated cylinders for range shift, front axle and PTO engagement.

The TC-1421 transfer case is a single-speed version of the TC-142.

	<u>TC-142</u>	<u>TC-1421</u>
RATINGS		
Maximum Input torque	14,000 Lbs. Ft.	15,000 Lbs. Ft.
Maximum Input Horsepower		450 HP
Maximum Input Speed		2300 RPM
RATIOS		
Direct	1:1	1:1
Underdrive	2.174:1	--
GEAR TYPE		
		Spur, Case Hardened
INPUT		
		2 3/4"-10 Spline
REAR AXLE OUTPUT		
		2 3/4"-10 Spline
FRONT AXLE OUTPUT		
		2 1/2"-10 Spline
DROP		
		16"
SHIFT MECHANISM		
		Integral Air Cylinder
LUBRICATION SYSTEM		
		Gear Pump - 30 PSI - 4 GPM
LUBRICANT		
		See Lubrication Section
OIL CAPACITY		
	18 Quarts	20 Quarts
WEIGHT		
	1,300 Lbs.	1,050 Lbs.
OPTIONS:		
		Full Power PTO.
		Direct Hydraulic Pump Drive.
		Proportioning Differentials (26/74) or (50/50) Torque Split.

1.3 ASSEMBLY VIEWS

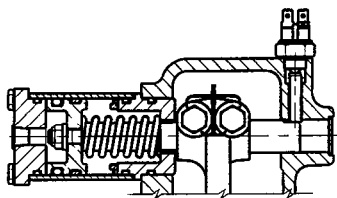

FRONT DECLUTCH SHIFT DETAILS

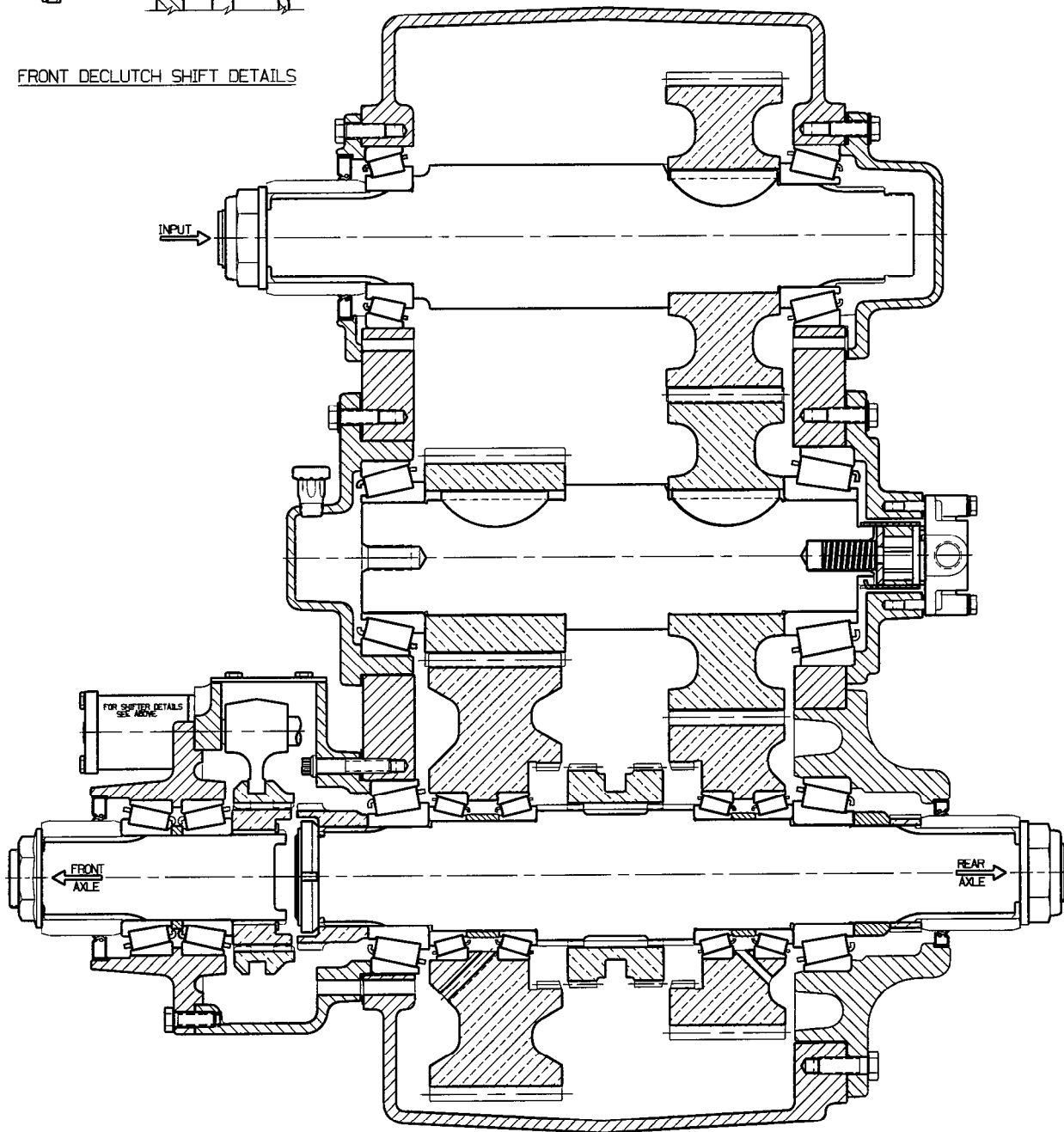

FABCO TC-142 TRANSFER CASE

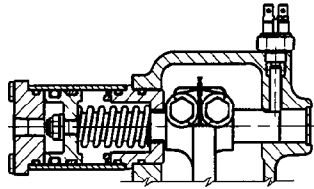

FRONT DECLUTCH SHIFT DETAILS

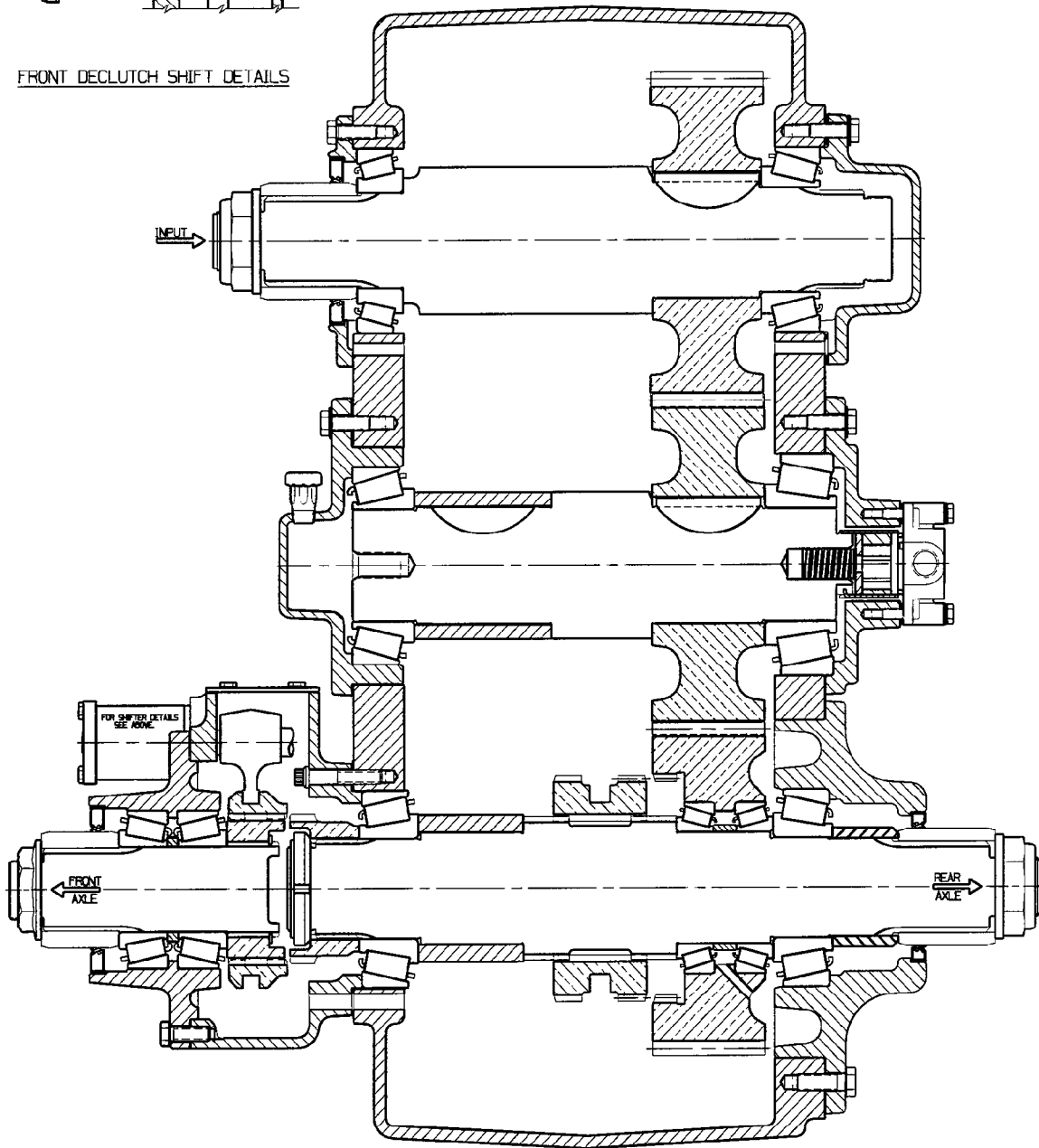

FABCO TC-1421 TRANSFER CASE

FABCO TC-142/TC-1421 TRANSFER CASE

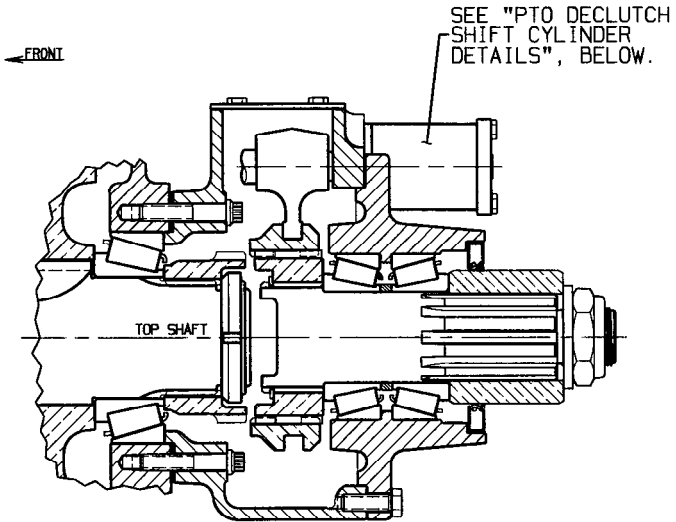

OPTIONAL PTO ASSEMBLY

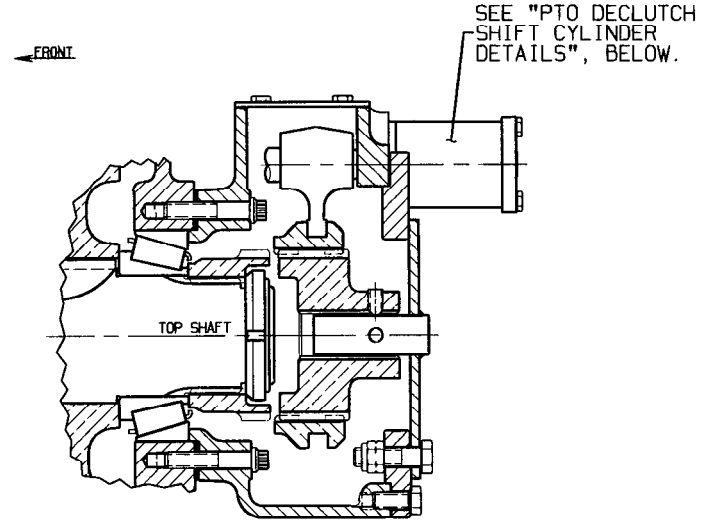

OPTIONAL DIRECT PUMP DRIVE WITH SHIPPING COVER

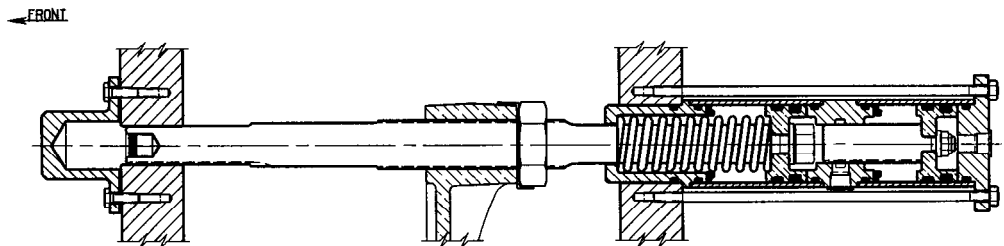

HIGH-NEUTRAL-LOW SHIFTER ASSEMBLY, TC-142

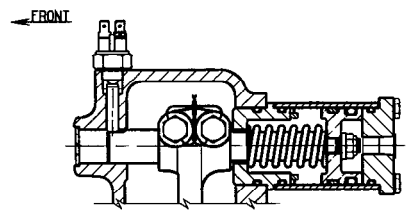

PTO DECLUTCH SHIFT CYLINDER DETAILS

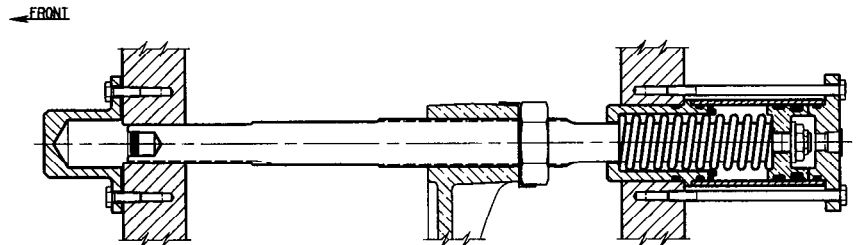

HIGH-LOW SHIFTER ASSEMBLY, TC-142
HIGH-NEUTRAL SHIFTER ASSEMBLY, TC-1421

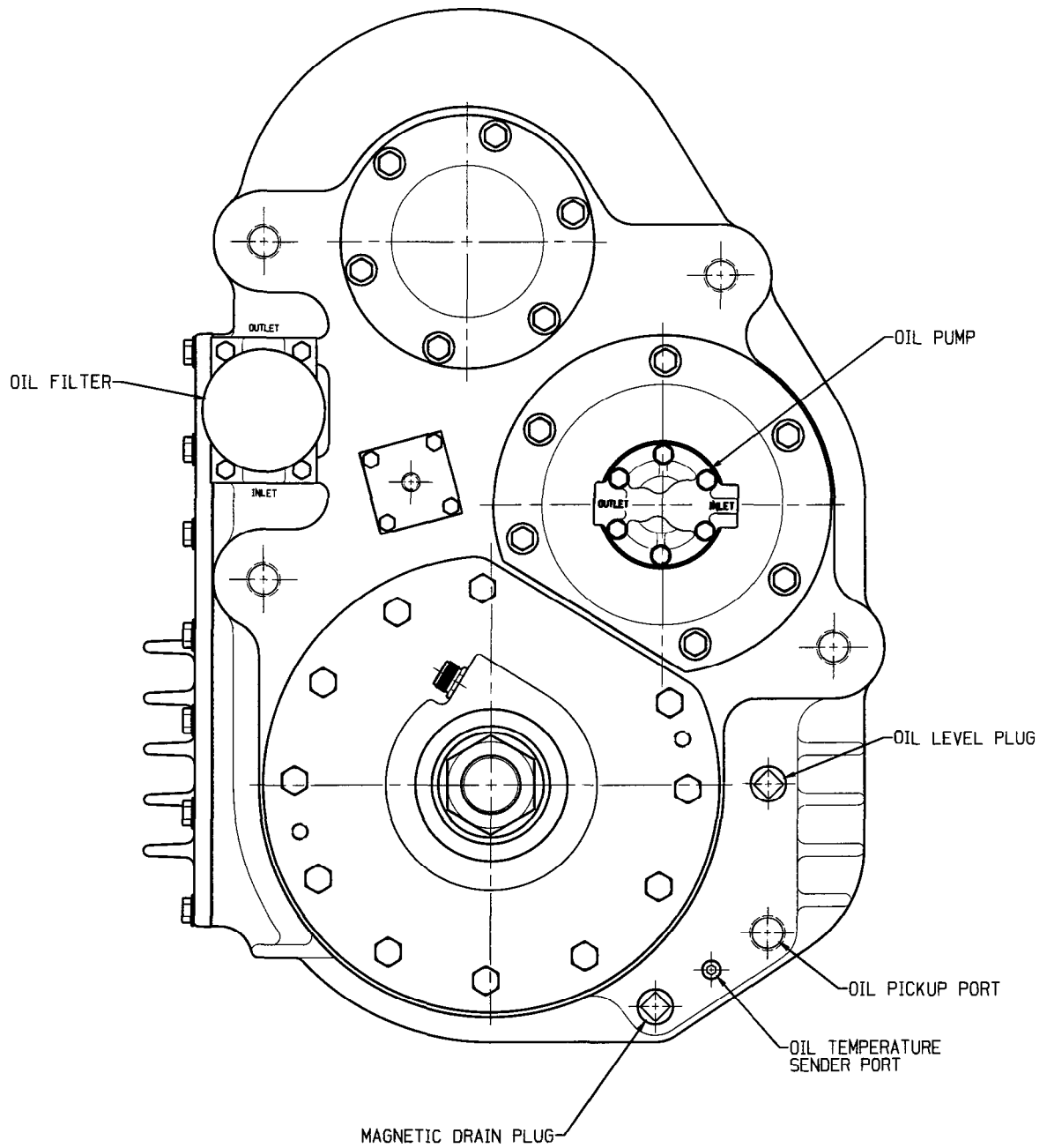

FABCO TC-142/TC-142I TRANSFER CASE
 REAR VIEW

2.0 LUBRICATION

2.1 RECOMMENDED LUBRICANTS

On-Highway Vehicles

1. Heavy Duty Engine Oil:

<u>Temperature</u>	<u>Grade</u>
Above + 10° F	SAE 50
Below + 10° F	SAE 30

Be sure to specify heavy-duty type meeting MIL-L-2104B specifications.

2. Mineral Gear Oil:

<u>Temperature</u>	<u>Grade</u>
Above + 10° F	SAE 90
Below + 10° F	SAE 80

Must be inhibited against corrosion, oxidation, and foam.

2.2 OFF-HIGHWAY & MINING

EQUIPMENT

1. Heavy-Duty Engine Oil:

<u>Temperature</u>	<u>Grade</u>
Above + 10° F	SAE 50
Below + 10° F	SAE 30

Be sure to specify heavy-duty type meeting MIL-L-2104B specifications.

2. Special Recommendation: For extreme cold weather where temperature is consistently below 0° F, use SAE 20W heavy-duty engine oil meeting MIL-L-2104B specifications.

NOTE: Extreme pressure (EP) oils are no longer recommended for use in Fabco transfer cases. Under certain operating conditions these oils might form carbon deposits on gears, shafts or bearings, possibly causing malfunctions and premature failure.

2.3 INSPECTION

The oil is to be maintained at the level of the fill plug at all times. Check at the following intervals:

Highway Service.....	1,000 Miles
Off-Highway Service.....	40 Hours

With every oil change, the shift cylinder air lines and valves should be inspected for leaks and possible malfunctioning. Low pressure conditions can cause partial clutch engagement which may result in premature wear or damage.

2.4 OIL CHANGE

The transfer case lubricant should be changed on all new transfer cases after the first 3,000 to 5,000 miles (on-highway), or the first 40 hours (off-highway); thereafter oil changes should be done at the following intervals:

On-Highway Service..... 10,000-15,000 Miles

Off-Highway Service
(Logging, dirt moving,
mining, and associated
operations) 500-750 Hours

The recommended oil change and inspection periods are based on the average use and operating conditions that the unit may encounter. It is suggested that the individual owner make a periodic lab analysis of the lubricant to determine contamination based on the unit's specific operating conditions. With this data, the oil change and inspection periods can be better determined.

2.5 DRAINING THE OIL

Draining is best accomplished after the vehicle has been operated briefly, allowing the oil to become warm and flow more freely. Remove both drain and fill plugs. Allow the housing to empty completely. Before the unit is refilled, it should be thoroughly flushed with clean flushing oil or kerosene.

If the unit is equipped with an oil pump, the lube oil filter should be replaced whenever the oil is changed. The element is of the spin-on type. A film of clean oil should be applied to the rubber gasket of the new element before installing. Do not overtighten.

2.6 REFILLING THE OIL

If the transfer case has been removed from the vehicle for service, it is best to refill the oil after the unit has been reinstalled into the vehicle.

Clean and replace the drain plug and fill the transfer case with the appropriate oil with the vehicle on level ground. Fill the transfer case to the level of the fill plug. On transfer cases equipped with a proportioning differential, it may take some time for the oil to flow into the main housing; therefore, it is necessary to fill the unit to the level of the fill plug, wait a few minutes, and top off the oil level. It may be necessary to do this several times. The plug should be installed only after the oil level has stabilized.

For each transfer case the oil capacity will vary somewhat, depending on the model and the inclination of the unit; therefore, always fill to the level of the fill plug. Do not overfill. Inspect for leaks.

2.7 OPERATING TEMPERATURE

The operating temperature of the transfer case should not exceed 250°F (120°C). Extensive operation at temperature exceeding 250° F will result in rapid breakdown of the oil and may shorten the transfer case life. If reduction of operating speed is not acceptable then the case may have to be equipped with an external oil cooler to maintain the operating temperature below 250° F.

The following conditions may contribute to excessive oil temperature.

1. A vehicle remaining stationary for extended periods while operating the power take-off.
2. A vehicle which is used in tropical or desert conditions.
3. A vehicle where extended body work or an accumulation of dirt and plant material may shield the case from air ventilation and circulation.
4. A vehicle that is operated for extended distances at high speed with the main transmission in overdrive.

3.0 CLEANING AND INSPECTION

3.1 CLEANING

Steam may be used for external cleaning of completely assembled units. Care must be taken to ensure that water is kept out of the assembly by sealing breather caps and other openings.

The transfer case housing, which is too large to conveniently clean with solvents, may be immersed in a hot solution tank containing a mild alkaline solution. Aluminum parts such as the carriers, caps, declutch housings, and air shift cylinder components must never be cleaned in any type of alkaline solution. Parts cleaned in a hot solution tank must be rinsed thoroughly to prevent damage by traces of alkaline material.

Parts with ground or polished surfaces, such as bearings, gears, shafts, and oil pump components should be cleaned with emulsion cleaners or petroleum solvents. An alkaline solution may damage the machined surfaces and such cleaning methods should be avoided.

3.2 DRYING AND CORROSION INHIBITION

Dry compressed air or clean, soft shop towels should be used to dry parts after cleaning. Bearings should never be spun dry with compressed air.

Dried parts should be immediately coated with a light oil or corrosion inhibitor to prevent corrosion damage. Parts which are to be stored should also be wrapped in heavy waxed paper or plastic bags and kept dust-free.

3.3 INSPECTION

Prior to reassembly, parts which are to be reused must be carefully inspected for signs of wear or damage. Replacement of such parts can prevent costly downtime at a future date.

All bearing surfaces, including roller bearing cups and cones, should be examined for pitting, wear, or overheating. Gears may also show pits, as well as scoring and broken teeth. Shafts may be nicked or marred, or have damaged threads. Parts which show any sign of damage should be repaired or replaced.

Inspect the rotor, housing, and idler of the oil pump (if equipped) for scoring. Inspect the drive tab of the rotor assembly. If any damage is noted, the pump cartridge assembly should be replaced as a unit.

Check all shift forks and slots in sliding clutches for wear or discoloration due to heat. Check the engaging teeth for a partial engagement wear pattern.

4.0 GENERAL INSTRUCTIONS

4.1 SAFETY

The servicing and maintenance of components from any automotive vehicle present possible hazards, every endeavor should be made to minimize the risks taken to successfully complete the task. For your protection we offer these warnings and suggestions.

1. When working on, around, or under the vehicle the parking brake should be securely applied and all wheels should be blocked to prevent wheel movement. Do not rely on the vehicle being in gear with a dead engine to prevent movement. All work should be performed on a flat level surface free of loose material.
2. When having to work under a vehicle it should be raised and supported with the appropriate frame stands or very secure blocking.

WARNING: Never work under a vehicle while supported only on a floor jack or hoist.

3. Be sure any lifting equipment has adequate capacity to raise the vehicle or component being lifted. This includes hydraulic floor jacks, crane type hoists, transmission jacks, and axle support dollies, etc. The weight of Fabco components is given in the front of the applicable service manual.
4. Caution must be exercised when cleaning the component or underside of the vehicle. Compressed air should not be used to blow dirt away as any harmful contaminant material on the bottom of the vehicle will be spread around the work area.

Appropriate solvents and cleaning solutions can be used in accordance with their labelling instructions or by referring to the Material Safety Data sheet (MSDS) that is available for each cleaner. Approved protective eyewear, gloves, masks and clothing should always be worn.

5. Fabco has not used Asbestos in any of its products manufactured since May of 1989 and was used only in axle brake linings prior to that time. See the separate Asbestos Warning if you suspect asbestos may be present on the vehicle or component in the area to be serviced.

4.2 ASSEMBLY PRECAUTIONS

1. Read the instructions completely before starting reassembly. Refer to the appropriate exploded view in the parts manual.
2. All parts must be clean. The gasket surfaces must be free of old gasket material. Do not reuse old gaskets.
3. Bearing cup bores, and shaft spline and bearing mounting surfaces, should be coated with Lubriplate or equivalent. This is necessary to reduce the possibility of galling.
4. All used oil seals must be replaced and the new oil seals should be coated with Loctite 601 or equivalent on their outer diameter prior to being installed in their bores. Their sealing lips should be coated with Lubriplate or equivalent to provide initial lubrication.
5. Any external cap screw not to be installed in a blind hole should have its threads coated with Permatex Form-A-Gasket #2 or equivalent non-hardening sealer to prevent an oil leak.
6. All threaded fasteners should be tightened to the torque specified in the torque chart.
7. Any sharp edges on the seal diameter of the universal joint yoke or companion flanges should be removed with emery cloth and should also be coated with Lubriplate or equivalent on the seal operating area before installation.
8. In many of the procedures, when a part is assembled with a press fit, it is recommended that the part be heated prior to installation. The part should be placed in an oven and heated to no more than 300 deg. F. Excessive heat may change the metallurgical properties of the part. Heated components should be allowed to cool to room temperature before end float measurements are made.

CAUTION: Although Fabco does not recommend its use in transfer cases, if formed in place gasket is used for repair, extreme caution must be exercised to prevent the compound from entering bearings, oil galleries, passages or tapped holes, all beads must be kept smaller than .125 inch diameter.

4.3 REMOVAL & INSTALLATION

4.3.1 REMOVAL

1. Remove fill and lower drain plugs and drain gear lubricant. Remove proportional differential drain plug and drain P.D. if so equipped.
2. Disconnect wires leading to indicator light switch, and temperature sensor, if used.
3. Disconnect and tag shift cylinder air lines.
4. Disconnect speedometer cable.
5. Disconnect drivelines at flanges or yokes.
6. If the transfer case is equipped with a PTO mounted hydraulic pump, remove four capscrews and slide pump out of PTO. Secure the pump to the frame to avoid damage to hydraulic lines. The pump should be secured in a position that will not hinder the removal of the transfer case.
7. Position a transmission jack of suitable capacity beneath the transfer case. The transfer case must be seated on the jack in a safe and firm position.
8. Disconnect transfer case mountings at rubber shock insulators. Since mounting designs vary, consult vehicle service manual.
9. After inspecting that all mountings and connections to the transfer case are disconnected lower the transfer case gradually to the floor. It is imperative that the transfer case is ALWAYS safely positioned on the transmission jack to safeguard the transfer case falling off the jack. Remove the transfer case from beneath the vehicle. It may be necessary to jack the truck up to allow room to remove transfer case.
6. Connect speedometer cable.
7. Connect shift cylinder air lines.
8. Connect indicator light and temperature sensor wires.
9. Fill housing with appropriate lubricant to correct level and install level plug.
10. Check transfer case for leaks around gaskets and seals.

NOTES

4.3.2 INSTALLATION INTO VEHICLE

1. Place transfer case on transmission jack, preferably lifting by means of eye bolts.
2. Position transmission jack underneath vehicle. Some vehicles may require that one side be jacked up in order to achieve sufficient clearance to replace the transfer case between the frame rails.
3. Raise the transmission jack to properly locate transfer case.
4. Connect transfer case mountings. Since mounting designs vary, consult vehicle service manual.
5. Connect drivelines.

5.0 DISASSEMBLY

Disassembly and assembly of the Fabco TC-142 transfer case is a relatively simple procedure, that can be made easier by the use of some very simple tooling. Details of all tooling is given in the tooling section for manufacture in your own facilities or Fabco Automotive may be contacted for a price and delivery quotation.

5.1 GENERAL DISASSEMBLY

The transfer case should be removed from the vehicle as discussed in the foreword to this manual.

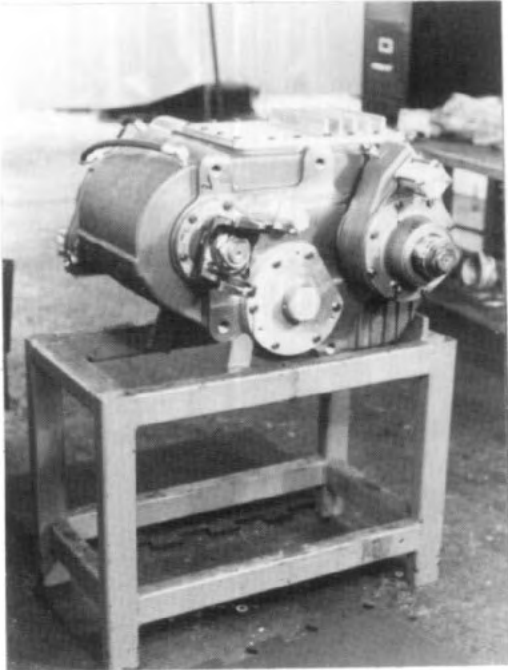

FIG. 5.1-1 Make a sturdy support structure to hold the case as shown. Construction may be of steel or wood. See sketch of suggested design in tool section.

NOTE: Versions of this transfer case can weigh up to 1,300 lbs.

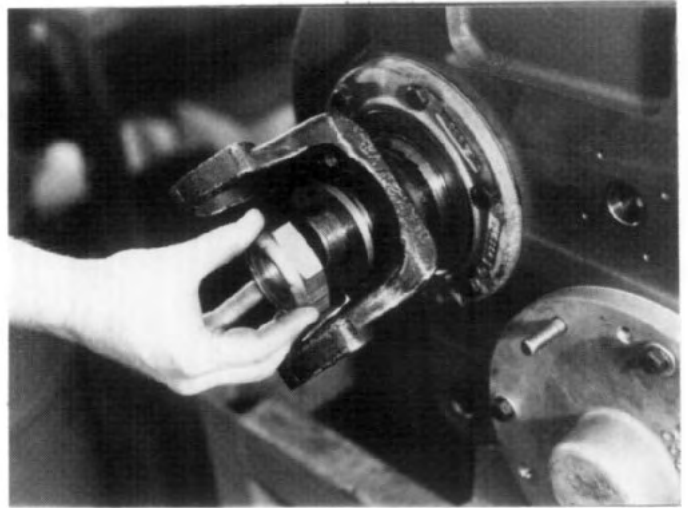

FIG. 5.1-3 Remove yoke or companion flange and seal carrier from upper shaft.

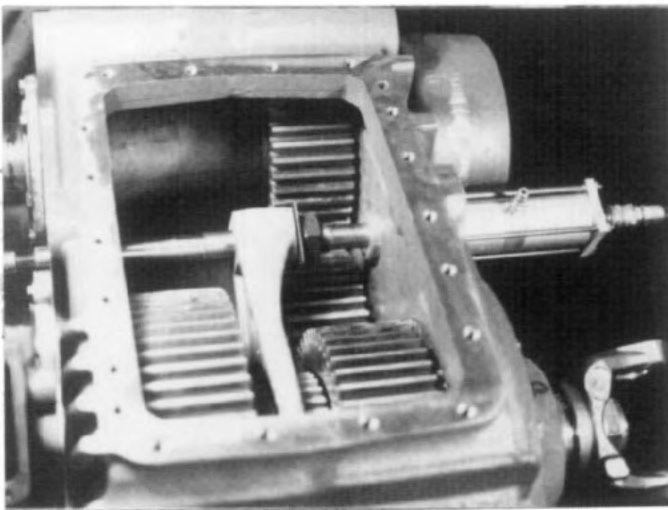

FIG. 5.1-2 Remove cover from case. Disassemble neutral and range shift cylinders, remove shift shaft, cap and shift fork. Remove lubricating pump, plumbing and filter.

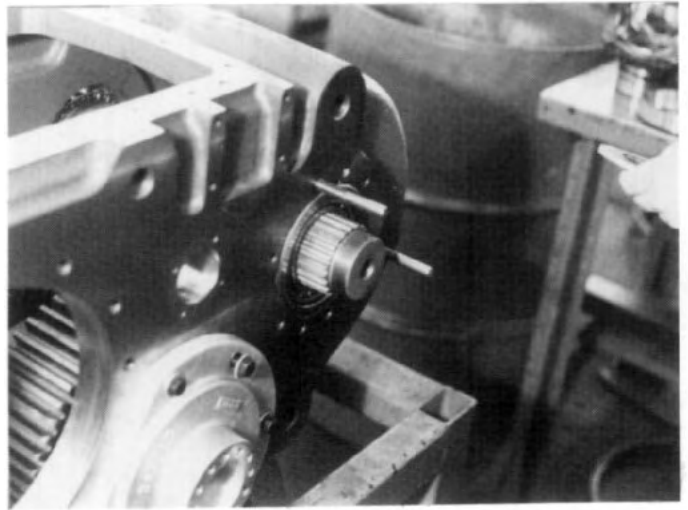

FIG. 5.1-4 Remove front drive declutch from lower output shaft and PTO declutch from rear of upper shaft.

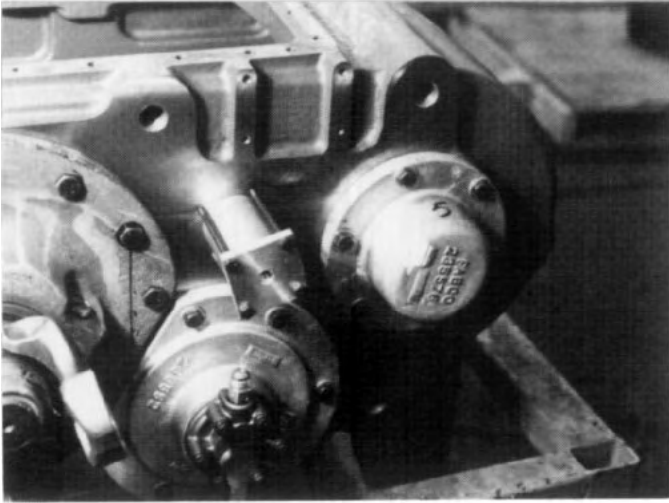

FIG. 5.1-5 If case not fitted with PTO remove end cap from rear of upper shaft.

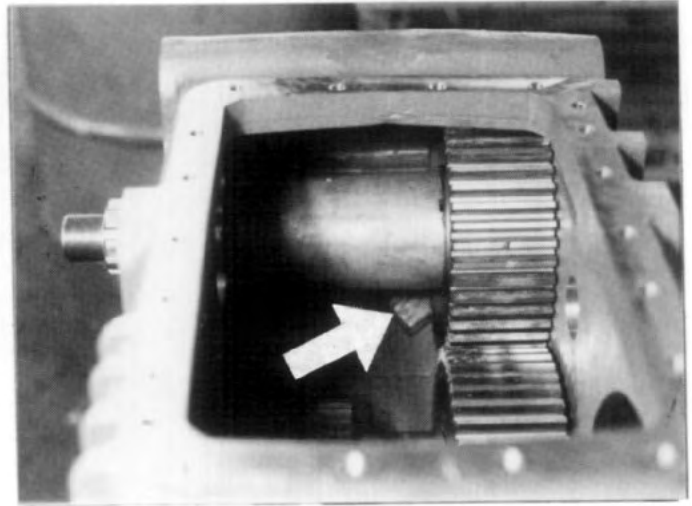

FIG. 5.1-8 Place small 2 x 4 x 2 inch piece of wood (arrow) between gear and housing.

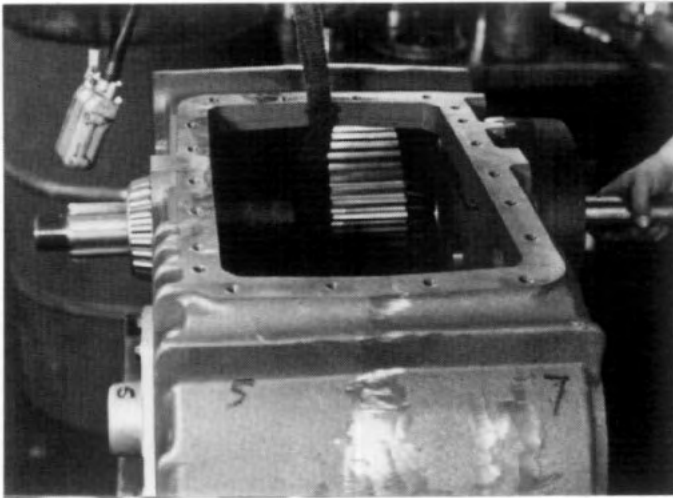

FIG. 5.1-6 Support upper shaft with sling or crane to take weight. With soft brass drift, drive upper shaft out front of case, far enough to remove front bearing cup.

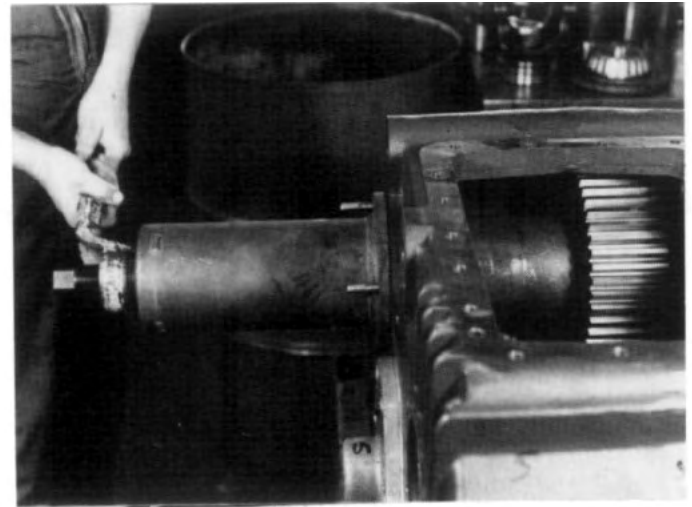

FIG. 5.1-9 Using tool number 866 623 assembled to threads on upper shaft, as shown, with 2.25 inch wrench, pull upper shaft from gear and housing.

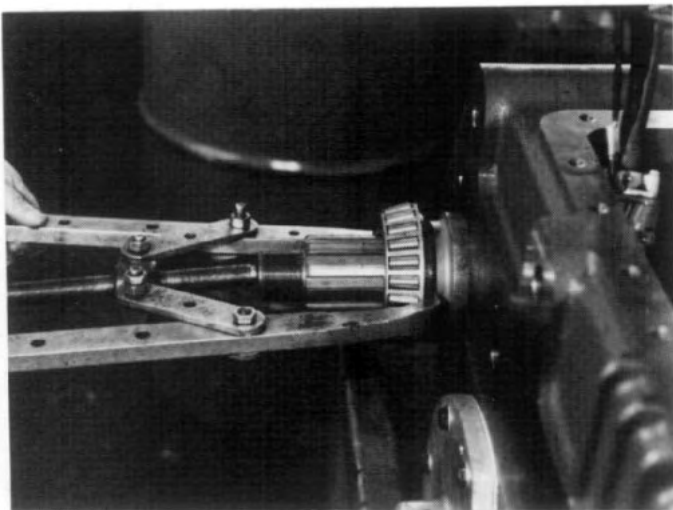

FIG. 5.1-7 Use suitable puller to remove bearing cone from front of upper shaft.

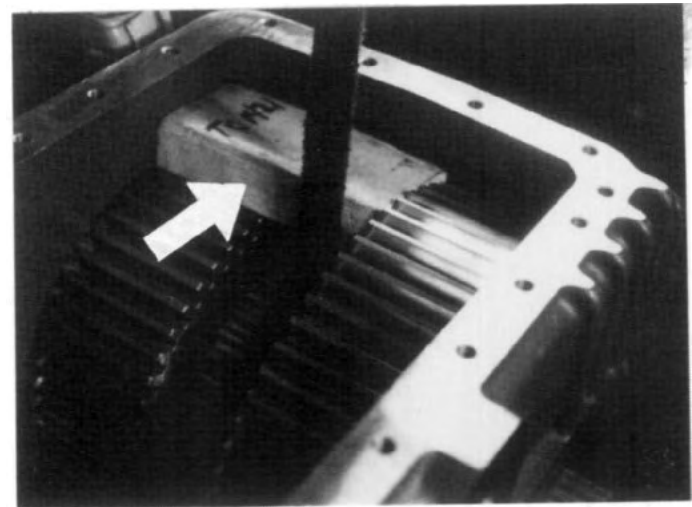

FIG. 5.1-10 Place sling around lower shaft clutch collar to take weight. Place 2 x 4 x 6 $\frac{3}{4}$ piece of wood between larger gear and rear of housing.

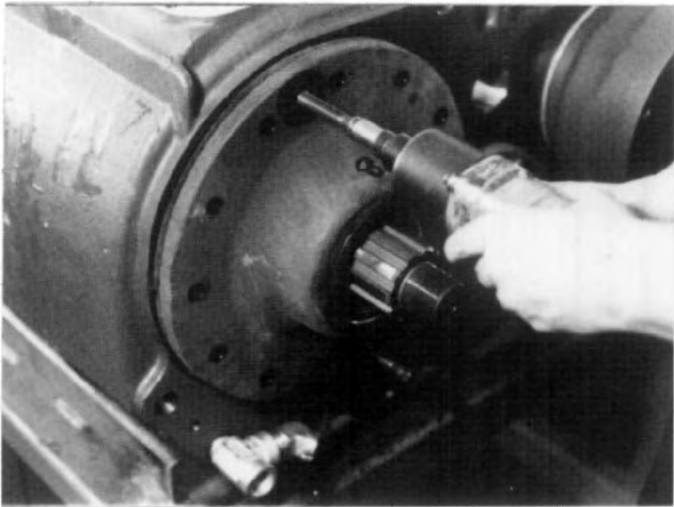

FIG. 5.1-11 Remove speedo adapter and speed pinion gear from carrier on rear of lower shaft. Use extractor bolts to remove carrier from housing



FIG. 5.1-12 While supporting lower shaft, use soft brass drift to drive lower shaft out of large gear.

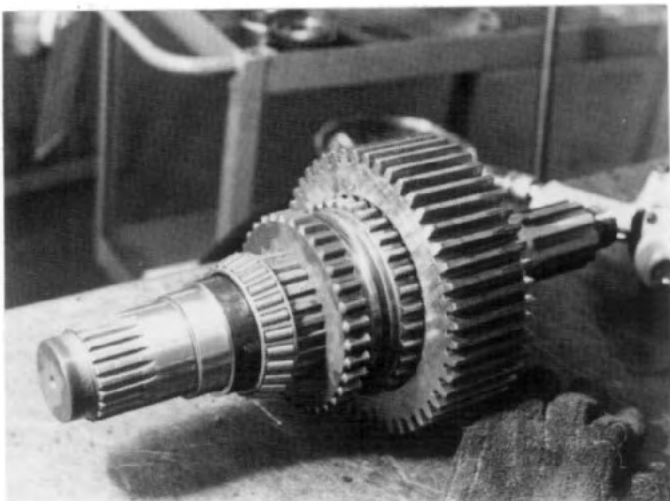

FIG. 5.1-13 Lower shaft removed from housing.

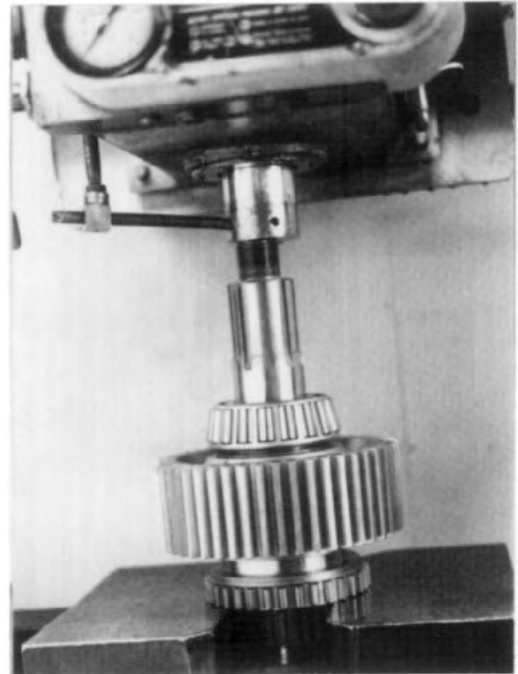

FIG. 5.1-14 Supporting gear and shaft on declutch collar on a suitable hydraulic press, push shaft out of gear.

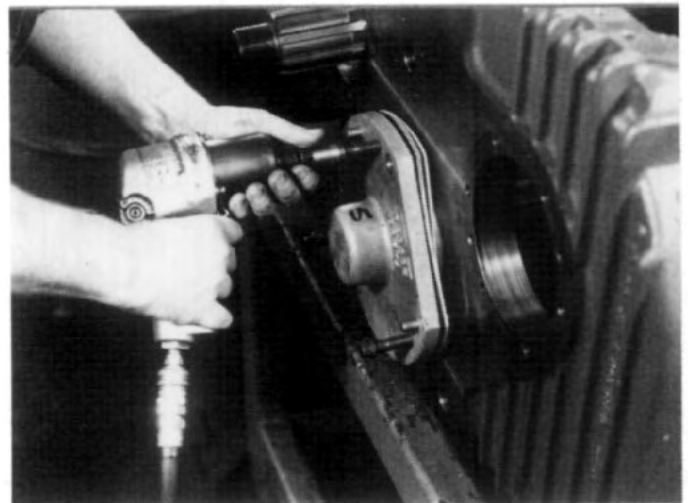

FIG. 5.1-15 Use extractor bolts to remove end cap from front of intermediate shaft.

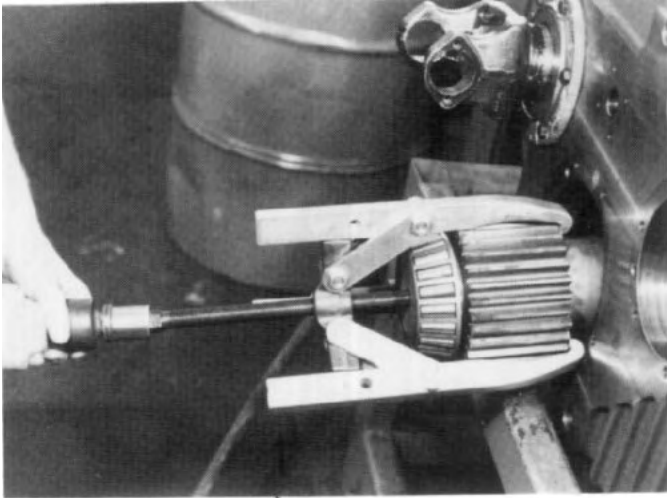

FIG. 5.1-16 Using suitable puller remove gear and bearing from front of intermediate shaft.

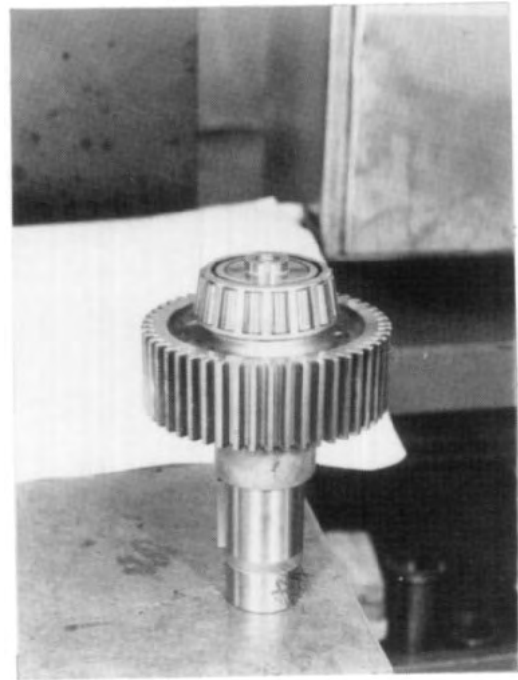

FIG. 5.1-18 Intermediate shaft removed from housing.



FIG. 5.1-17 With sling or lifting device remove intermediate shaft from housing.



FIG. 5.1-19 Use suitable hydraulic press to disassemble shaft from intermediate gear.

5.2 FRONT DRIVE AND PTO DECLUTCH DISASSEMBLY

NOTES

Remove other components as required. Clean and dry all parts using precautions indicated in the foreword to this manual. Examine all parts for wear or damage from misuse or poor handling. Discard and replace any parts that appear to have any damage. All bearings that have had disassembly loads through the rollers and races must be discarded and replaced.

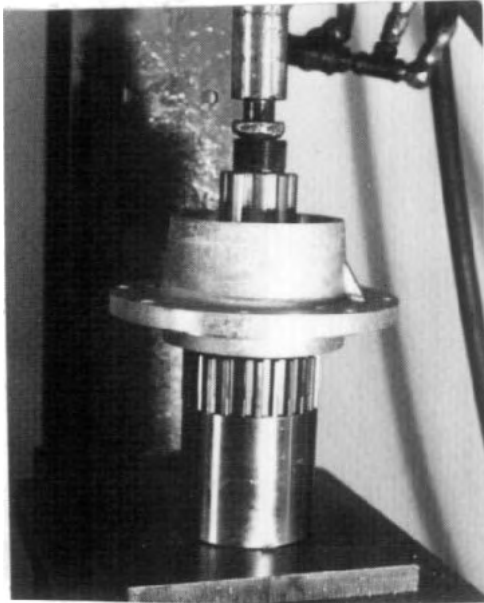

FIG. 5.2.-1 Remove drive yoke or companion flange from output shaft. Remove carrier held by 8 cap screws from clutch housing. Disassemble output shaft from carrier with suitable hydraulic press. Remove seal from carrier.

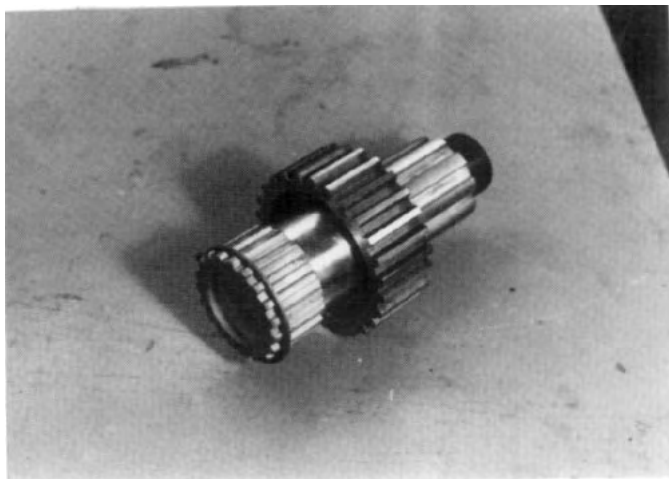

FIG. 5.2-2 Output shaft may be disassembled by pressing clutch gear off shaft and removing snap ring. Remove shift cylinder parts, shift fork and clutch collar from clutch housing, also remove shift switch and pin from housing. Remove clutch housing from transfer case housing.

6.0 ASSEMBLY

Make sure all parts are clean, dry and lint free. Any traces of storage wax or paper should be removed. Leave bearings in wrapper until ready to use. Do not handle any more than is absolutely necessary.

Parts should be given a light smear of lubrication, unless indicated otherwise, on all mating surfaces. Lubriplate is an acceptable grease or a substitute may be made using a mixture of chassis grease and 30W motor oil. The mix should be thin enough to readily apply with a small brush.

6.1 INTERMEDIATE SHAFT SUB-ASSEMBLY & INSTALLATION



FIG. 6.1-1 Using a domestic electric oven or other suitable heater, place both gears from intermediate shaft inside for approximately 15 minutes. Other heating devices can be used, but gear temperature should not be allowed to exceed 300° F.

NOTE - Do not use an acetylene torch to warm parts as parts can easily be damaged.



FIG. 6.1-2 While gears are warming, assemble keys into keyways in intermediate shaft. These should be a light drive fit and a soft brass drift may be used.

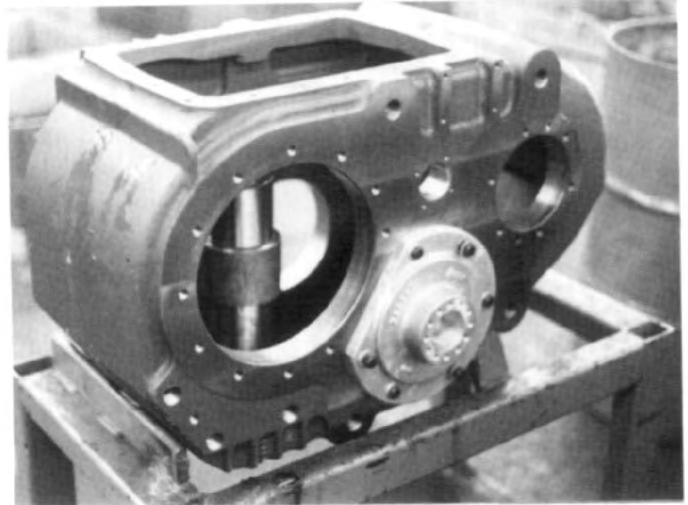

FIG. 6.1-3 Stand intermediate shaft in housing on end with small pump drive diameter and drive slot upwards. Position shaft such that key is readily visible. Place the appropriate bearing cones in heater for approximately 3 minutes.

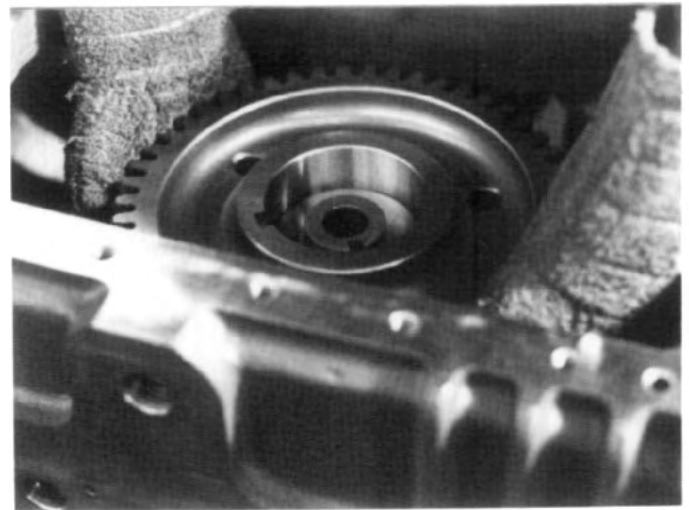

FIG. 6.1-4 Using heat protective gloves take large gear from heater, orient keyway suitably and lower onto intermediate shaft. Be sure gear is fully on shaft.



FIG. 6.1-5 Immediately repeat process with the warmed larger bearing cone.

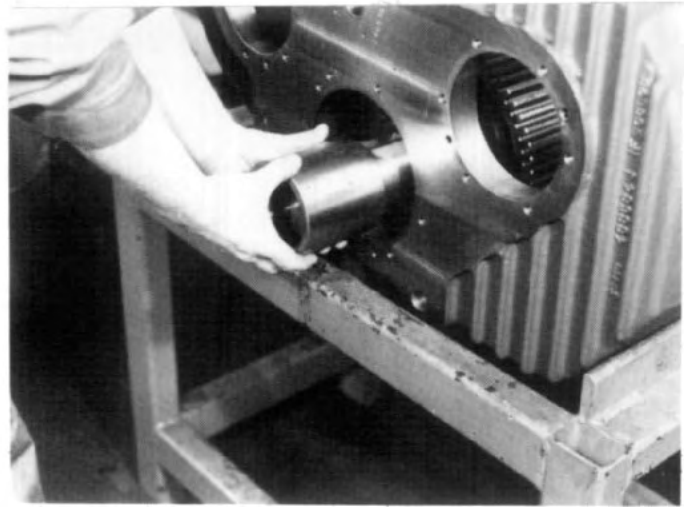

FIG. 6.1-8 On the TC-1421 a spacer sleeve is used in place of the small gear on the TC-142.

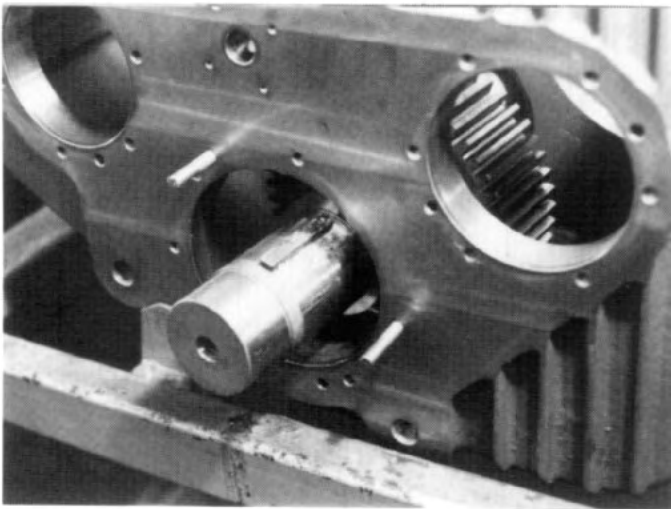

FIG. 6.1-6 Quickly move shaft so that other end is extended out of front opening in housing with key at the uppermost position.

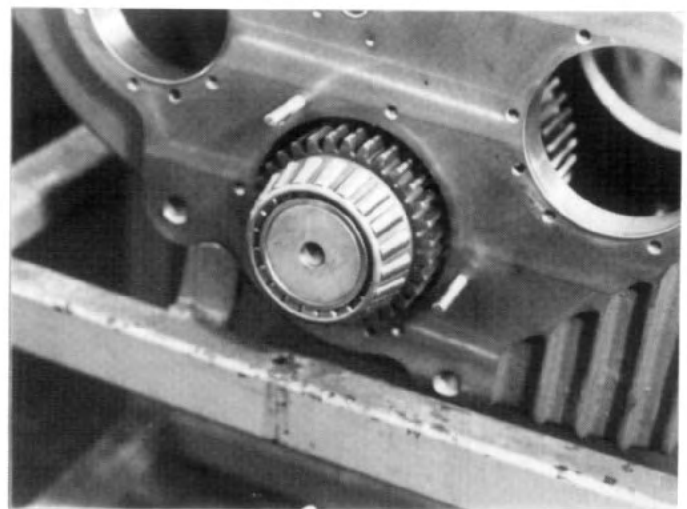

FIG. 6.1-9 Repeat assembly process with remaining smaller bearing cone. Be sure bearing is fully on shaft.

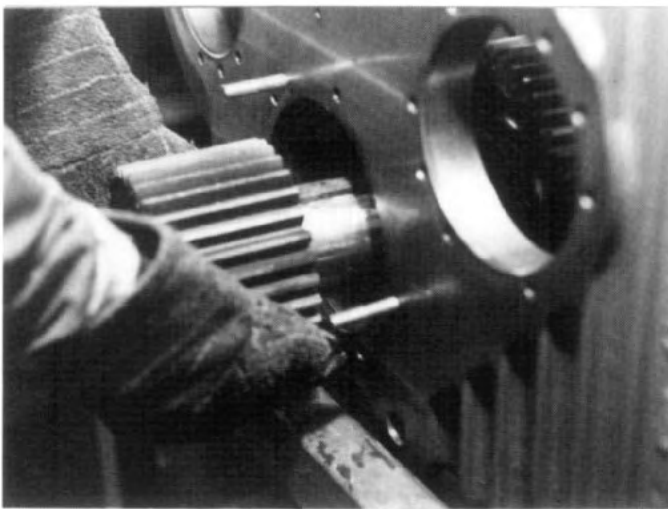

FIG. 6.1-7 Take smaller gear from heater, orient keyway and slide onto end of intermediate shaft. Be sure gear is fully onto shaft against shoulder.

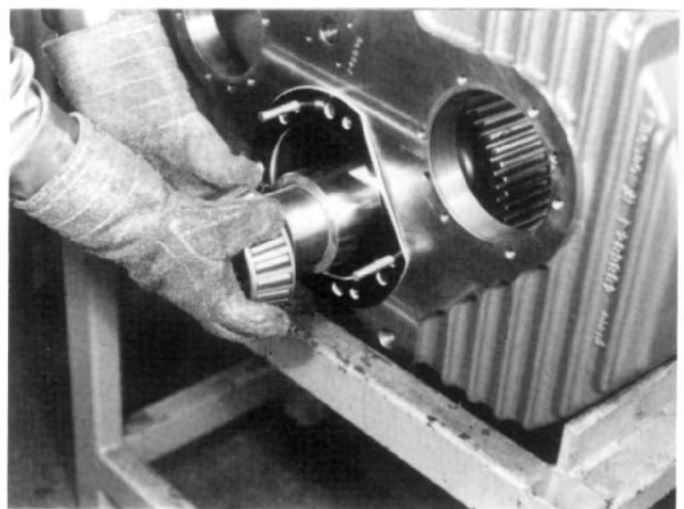

FIG. 6.1-10 The intermediate shaft bearing on the TC-1421 is handled in the same manner as the TC-142, except spacer sleeve is used in place of small gear and key.
NOTE: Spacer sleeve should not rotate after bearing is seated.

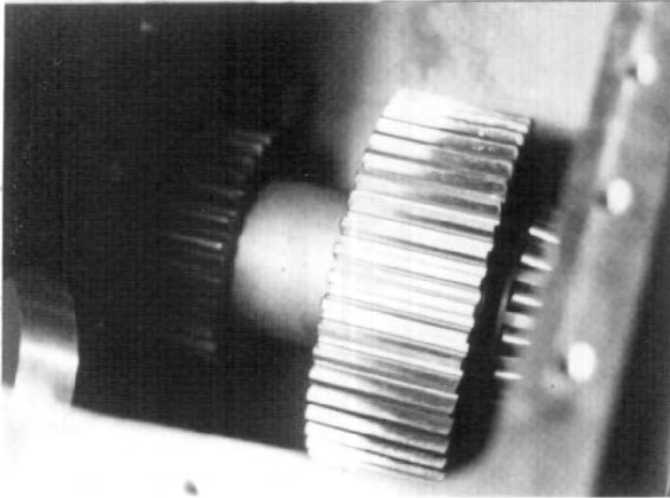

FIG. 6.1-11 Leave intermediate shaft lying in housing and allow to cool down.

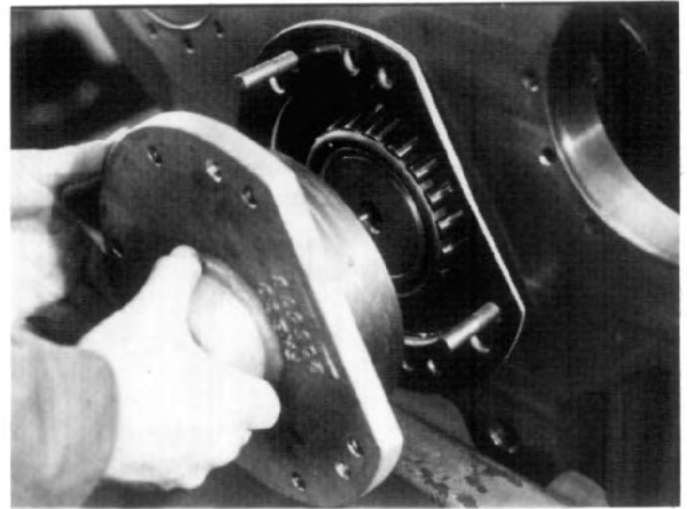

FIG. 6.1-13 Press smaller bearing cup into end cap. Using approximately .150 inches pile of shims, assemble end cap to front of housing. Extended length bolts with the heads removed can be used as simple guides to support and locate all gaskets, shims and end caps as required.

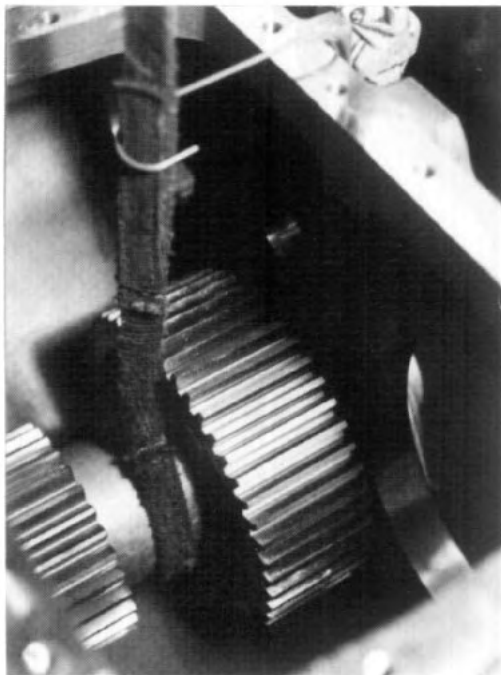

FIG. 6.1-12 Lightly grease intermediate shaft housing bores and tap large bearing cup into place using a soft drift or suitable driver, while supporting weight of shaft on a sling. Make simple wire retainer to hold sling close to large gear and rear of housing. Mount lubricating pump mounting cap to rear face of housing. Tap front of shaft to be sure cup is seated.

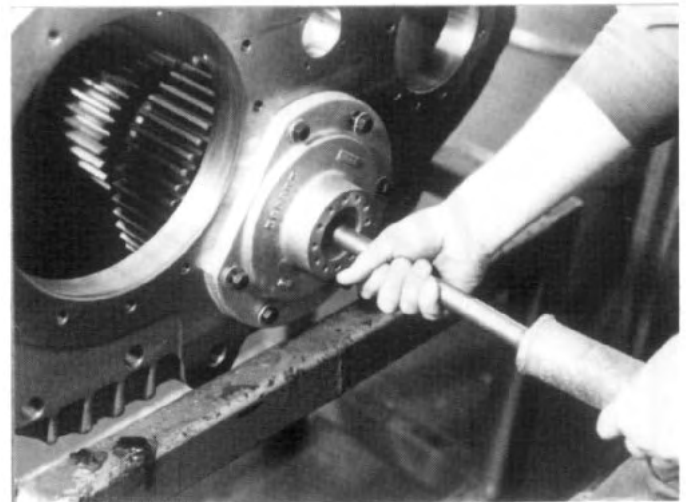

FIG. 6.1-14 Tap end of shaft with soft drift to be sure caps and bearings are seated. Add cap screws to each end cap to retain assembly. End float adjustment will be discussed in later section.

6.2 UPPER SHAFT ASSEMBLY



FIG. 6.2-1 Place upper shaft gear in heater for approximately 15 minutes. Add upper shaft bearing cones for last 3 minutes of heating time. While gear is heating add key to upper shaft.

With heat resistant gloves place upper gear in housing with teeth engaged with intermediate large gear, position keyway where readily visible. Quickly place 2x4x2 inch piece of wood between gear and housing.

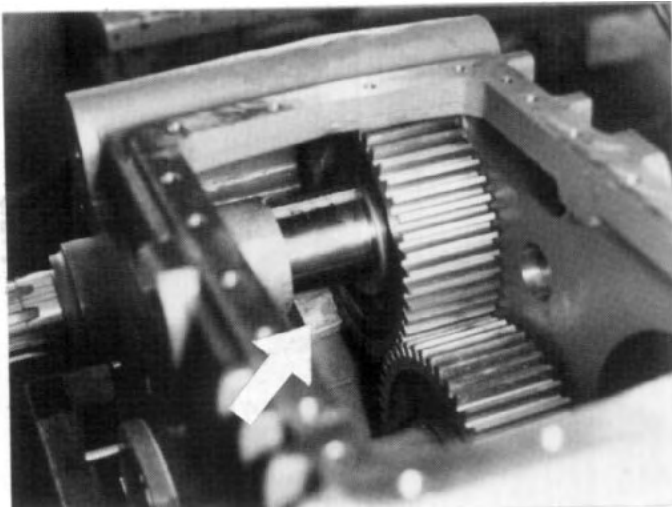

FIG. 6.2-2 Orient upper shaft key to match keyway in gear and slide shaft into gear. Be sure shaft is fully seated in gear.



FIG. 6.2-3 Still wearing gloves quickly assemble bearing cone to rear of upper shaft.

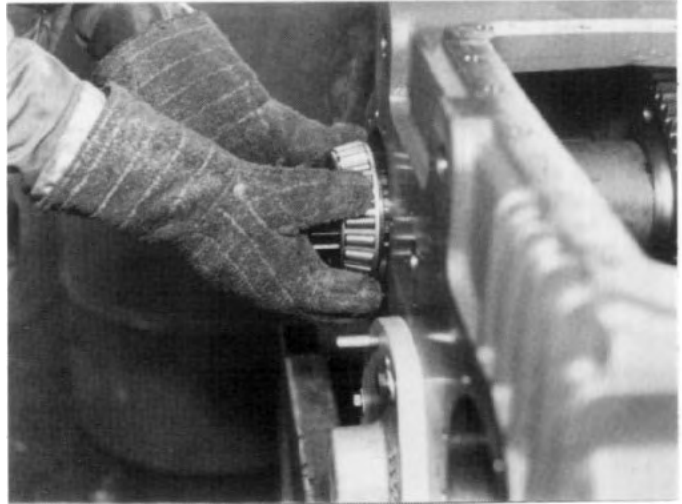

FIG. 6.2-4 Repeat process with front bearing cone on upper shaft. Be sure cones are against shoulders.

NOTE - Do not forget to remove wooden block from housing after assembly.



FIG. 6.2-5 Assemble bearing cup, .150 inch shim stack and declutch gear, if required, to rear end of shaft.



FIG. 6.2-6 If fitted with a PTO, drive the welch plug into the declutch housing, first coating with Permatex sealer. Be sure to use the correct housing, not mistaking the housing from the front drive declutch.

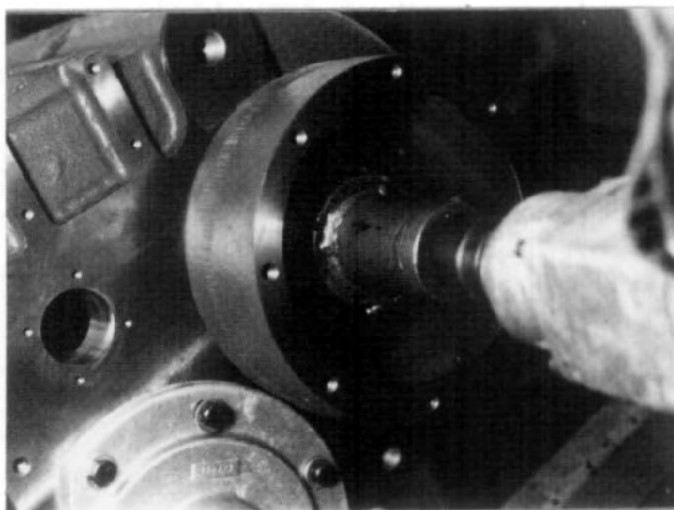

FIG. 6.2-7 Mount declutch housing temporarily to case with 2 cap screws and tighten locknut to specified torque with special wrench, tool number 8661600 003

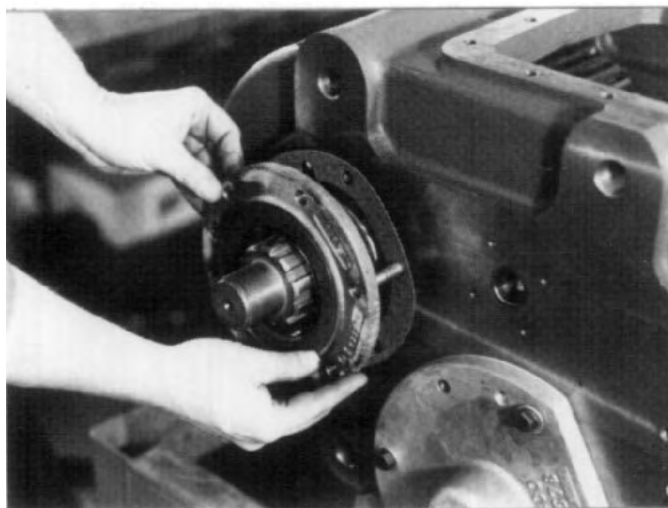

FIG. 6.2-8 Press seal into front carrier, and assemble with gasket to front of housing.



FIG. 6.2-9 Tighten cap screws to specified torque. Adjustment of bearing end float will be discussed in later section.

6.3 LOWER SHAFT SUB-ASSEMBLY

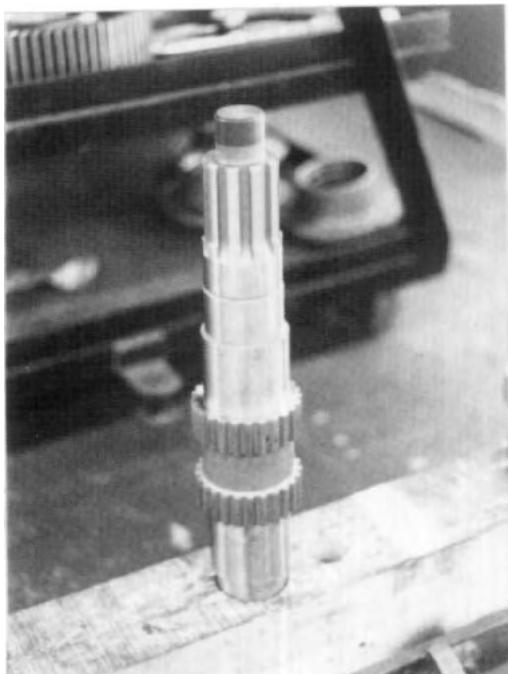

FIG. 6.3-1 Place short end of lower shaft into assembly stand. Tool number 866 647.



FIG. 6.3-3 Tap smaller gear internal bearing cone lightly to get started on shaft, when aligned it should slip relatively easily.

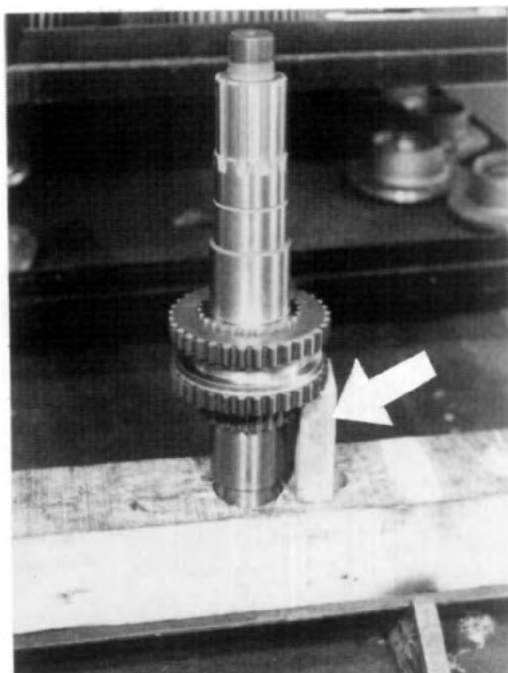

FIG. 6.3-2 Slide clutch collar over spline and hold at correct height by using 2x4x5¼ inch block of wood.



FIG. 6.3-4 Press bearing cups into both gears.

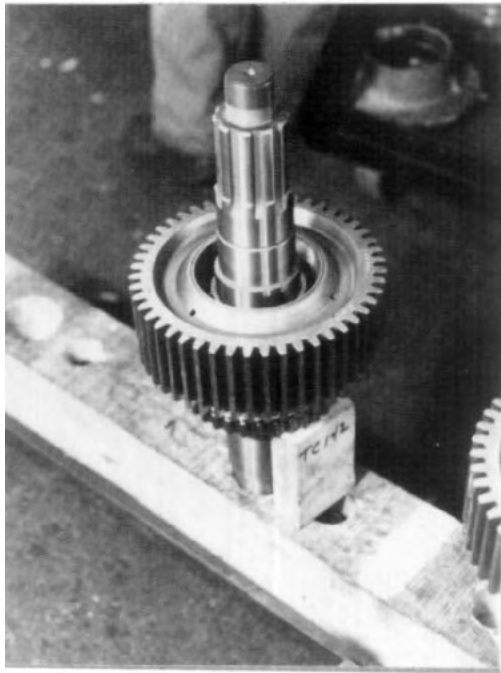

FIG. 6.3-5 Slip smaller gear over shaft, note direction of clutch teeth. Add inner bearing spacer to shaft. Slide second bearing onto shaft into bearing cup. Be sure gear rotates easily.

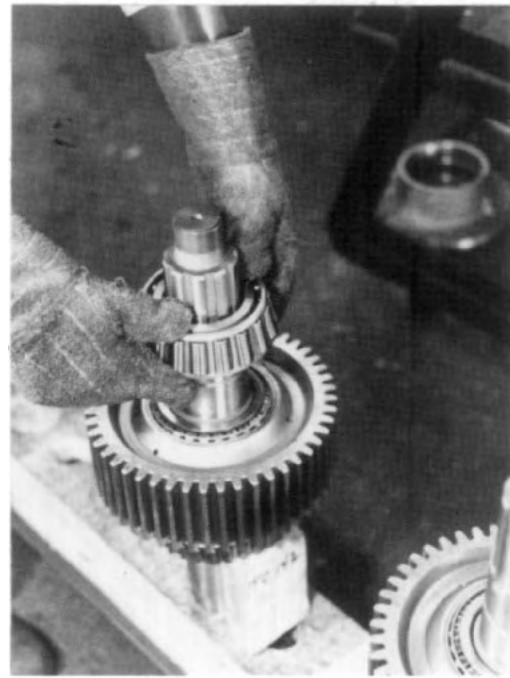

FIG. 6.3-7 Place shaft bearing in heater for 3 minutes, then slide over shaft.

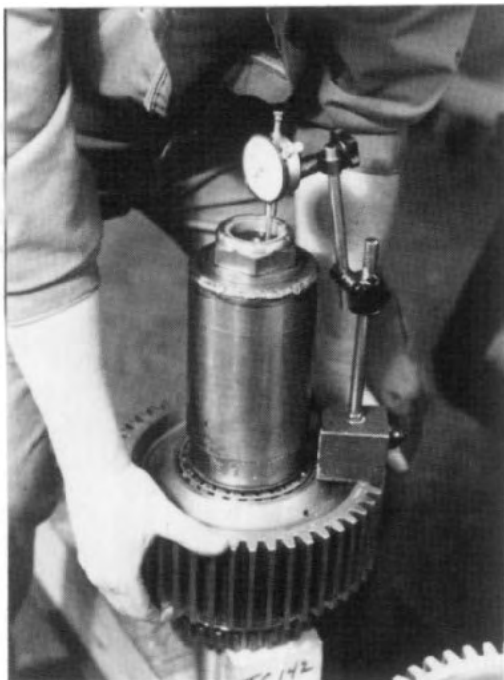

FIG. 6.3-6 Using tool number 866 649 assembled to shaft with locknut check end float with dial indicator as shown. Total end float should be .003 to .008 inches. Replace spacer between bearings with one of suitable size to provide correct end float.

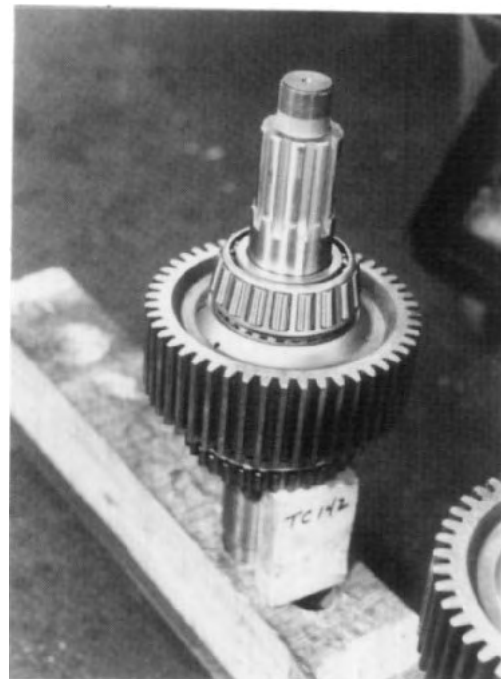

FIG. 6.3-8 Make sure bearing is seated against cone of inner bearing as this holds assembly together.

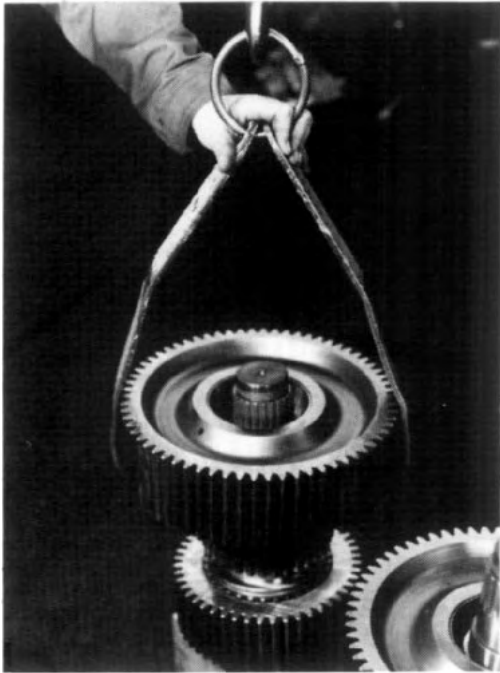

FIG. 6.3-9 When bearing is cool, reverse shaft in fixture and repeat procedure with the larger gear, but do not install the shaft bearing. Use hooks, number 866 648 to handle large gear.



FIG. 6.3-11 Assemble tool number 866 650 to shaft and gear and check end float in bearings with dial indicator as shown. Total end float should be between .003 and .008 inches. Replace spacer between gear bearings if necessary to provide correct end float.

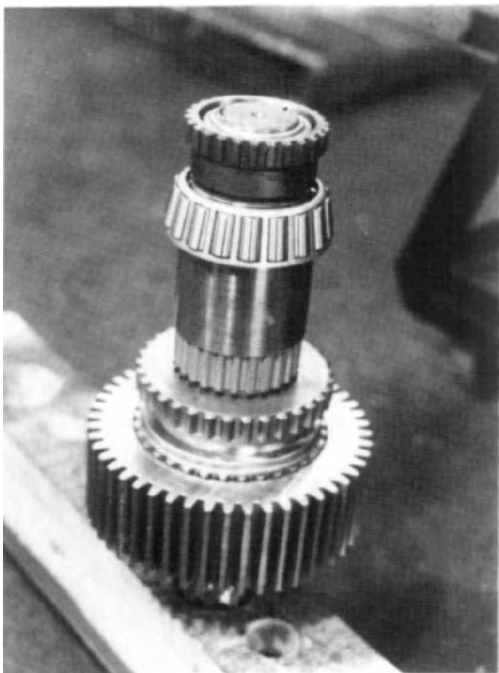

FIG. 6.3-10 On the TC-1421 a spacer sleeve is used in place of the larger gear and bearing assembly. When bearing is pressed home, the sleeve must not rotate.

NOTES

6.4 LOWER SHAFT INSTALLATION IN HOUSING

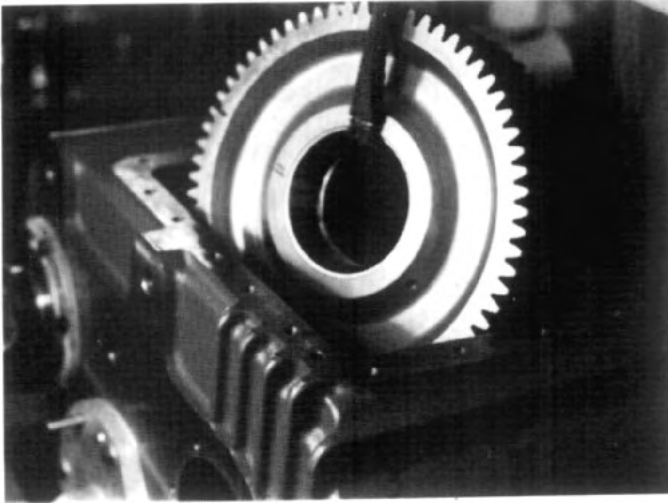

FIG. 6.4-1 After bearings are fully adjusted for end float of gears on the lower shaft, remove the larger gear from shaft and place inside housing. Clutch teeth should be toward center of housing.

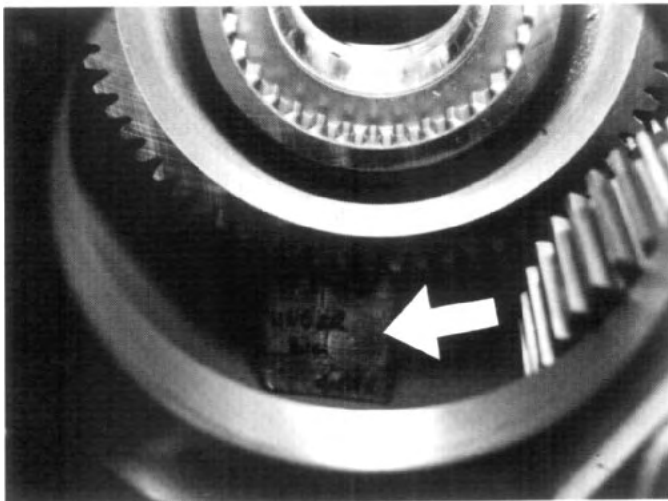

FIG. 6.4-2 Engage gear with small gear on the intermediate shaft and place 2x4x4¼ block of wood (arrow) under gear to align bearings with housing bore.

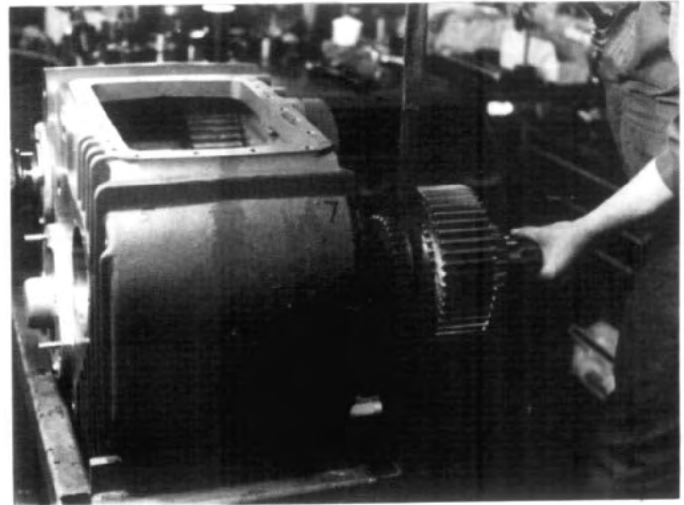

FIG. 6.4-3 Support remaining assembly of lower shaft on sling at clutch collar groove and enter short end into large housing bore and into bore of large gear.

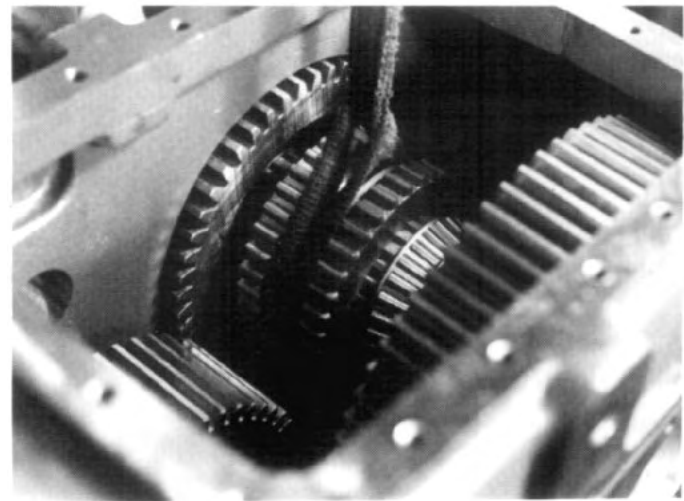

FIG. 6.4-4 Transfer sling to inside of housing.

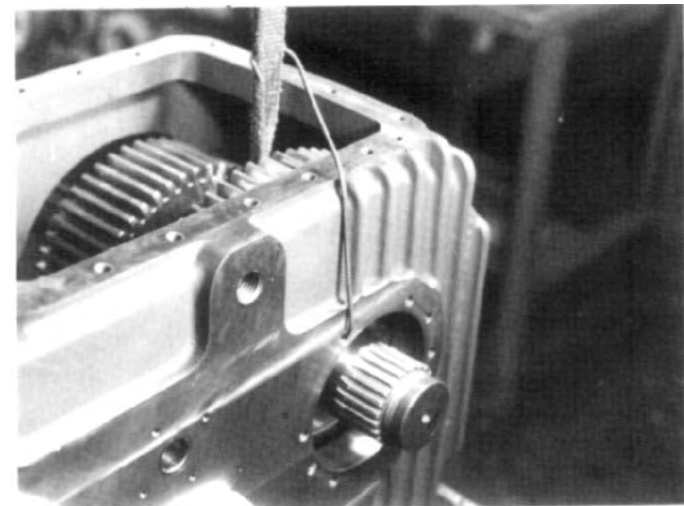

FIG. 6.4-5 Slide shaft as far forward into large gear and out of front of housing as is possible. Make simple wire clip to restrain sling in forward position. Assemble spacer and outer bearing into large gear.



FIG. 6.4-6 Heat remaining shaft bearing cone in heater for approximately 3 minutes and with heat resistant glove slide bearing on shaft to butt against bearing cone under gear.

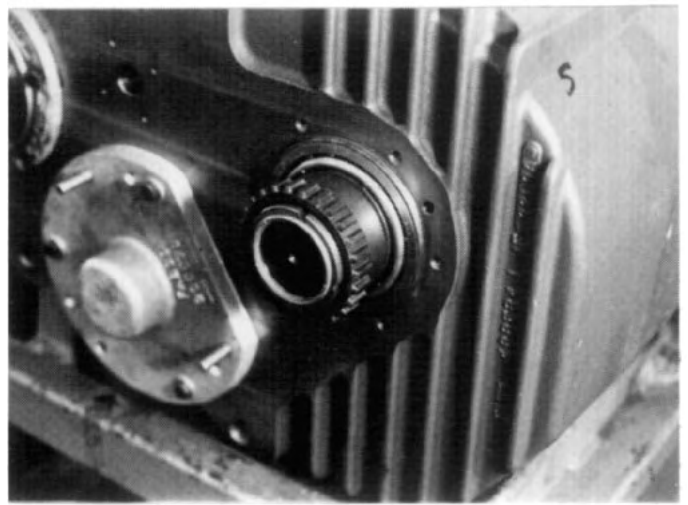

FIG. 6.4-9 Add front drive clutch gear and locknut, and tighten to appropriate torque.



FIG. 6.4-7 Allow bearing to cool and tap bearing cup into housing bore.

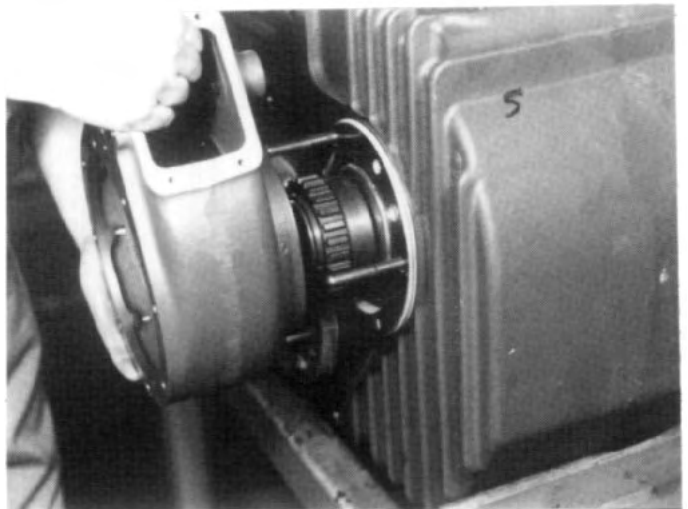

FIG. 6.4-10 Add declutch housing with plug installed as previously indicated, being sure correct housing is used, with a .150 pile of shims in place. Mount temporarily with 2 cap screws, left loose until speed carrier cap screws are torqued.

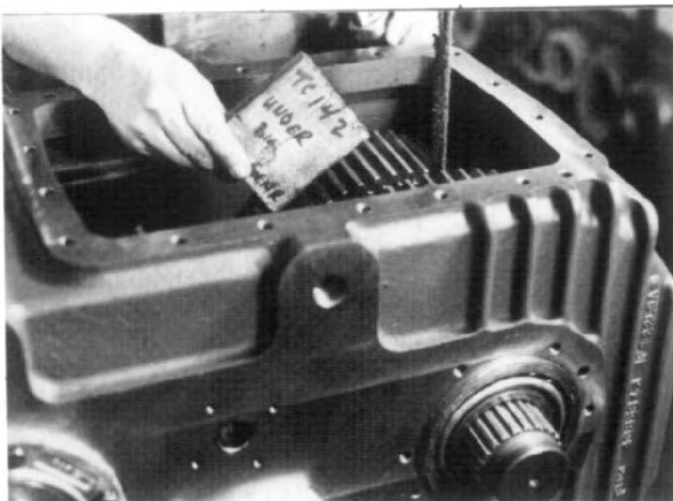

FIG. 6.4-8 Remove wooden block from under gear.

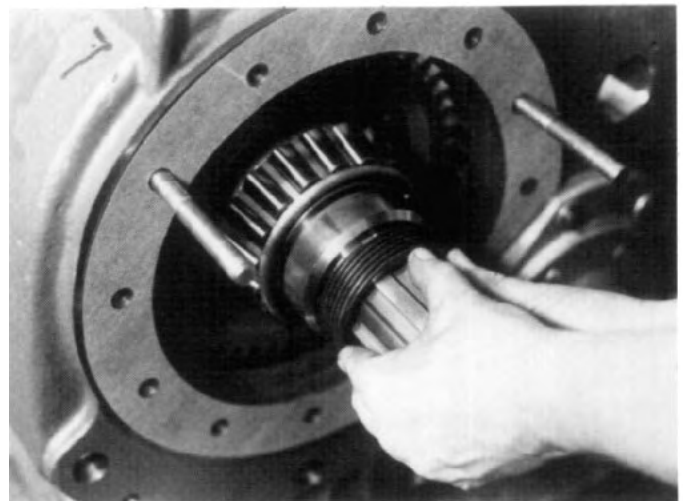

FIG. 6.4-11 Add, shaft spacer and speed drive gear to rear of lower shaft.

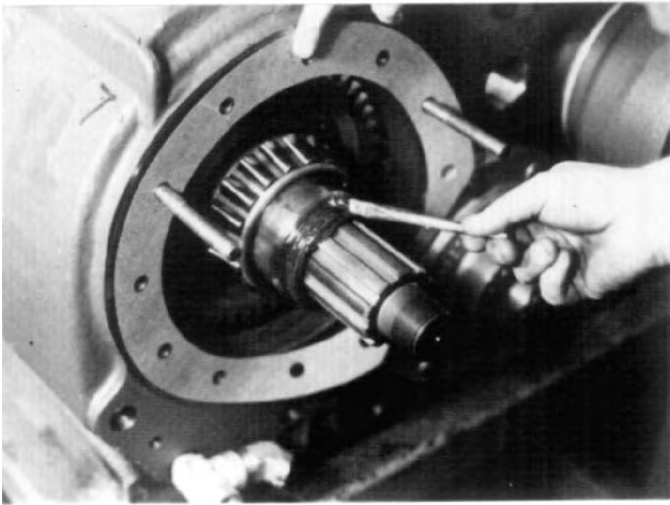

FIG. 6.4-12 Smear the speed drive gear liberally with the grease and oil slurry.



FIG. 6.4-14 Seat oil seal in speed carrier.



FIG. 6.4-13 Press bearing cup into speed carrier with suitable press.



FIG. 6.4-15 Place carrier and gasket on locator studs and assemble into large opening in rear of housing.

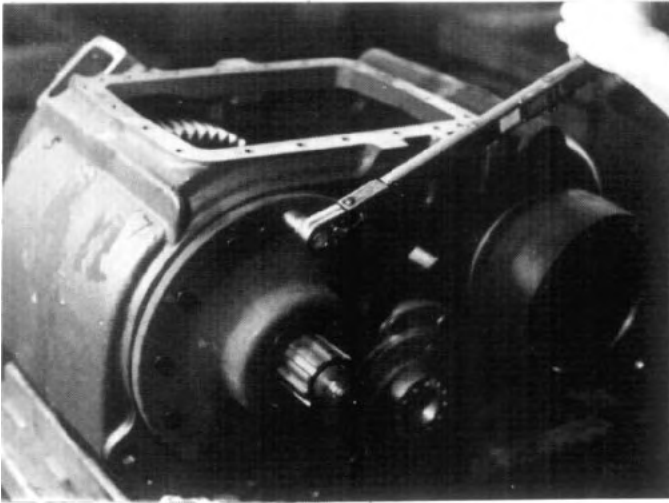

FIG. 6.4-16 Tighten speedo carrier mounting bolts to the appropriate torque.

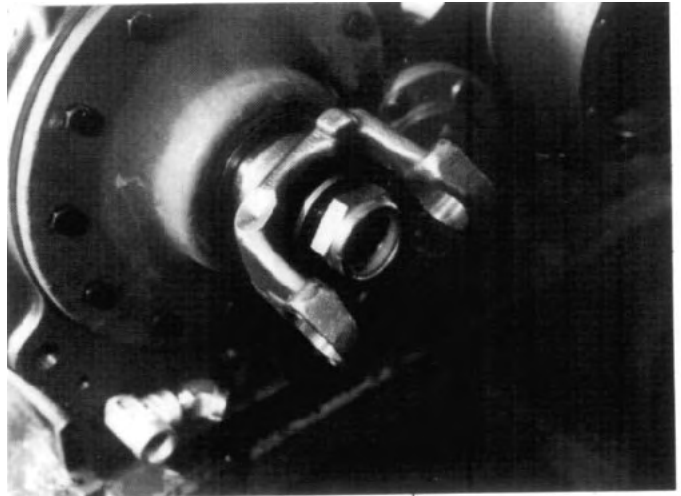

FIG. 6.4-19 Examine yoke or companion flange hub diameters for nicks or sharp corners, remove with emery cloth. Grease seal diameter and carefully slide hub into seal, using extreme caution not to damage seal lips.

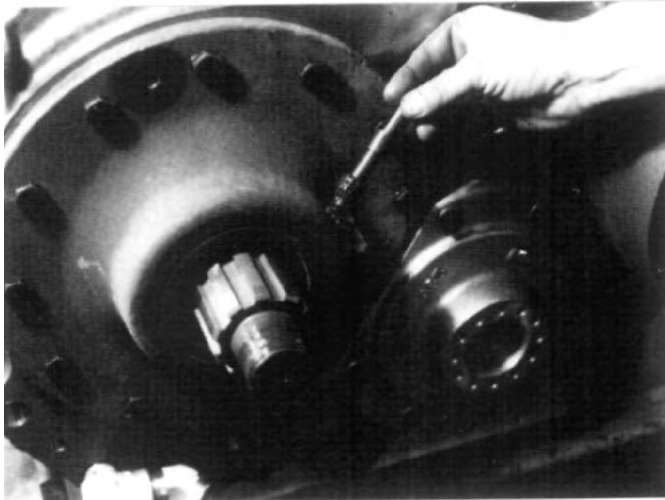

FIG. 6.4-17 Smear speedo pinion gear teeth with grease and place into carrier. Be sure teeth engage drive gear properly.

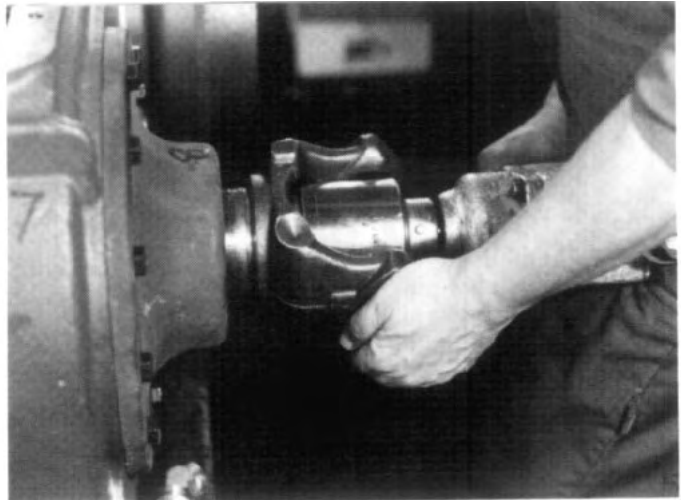

FIG. 6.4-20 Add washer and nut to shaft and tighten to appropriate torque. Adjust bearing end float as indicated in bearing adjustment section.

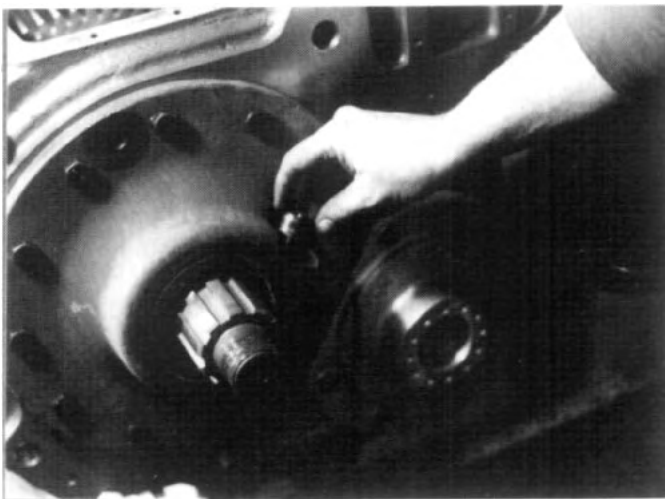

FIG. 6.4-18 Grease bore of speedo adapter and slide over pinion, screw into carrier, tighten to appropriate torque.

6.5 SHAFT & BEARING END FLOAT ADJUSTMENT

All the bearings in the TC-142 Transfer Case are adjusted to allow end float of the shaft in its bearings. Absolutely no preload or tight bearings should be used. The bearing and shaft assemblies must be allowed to cool to normal room temperature the same as the housing and carriers before making any adjustments.

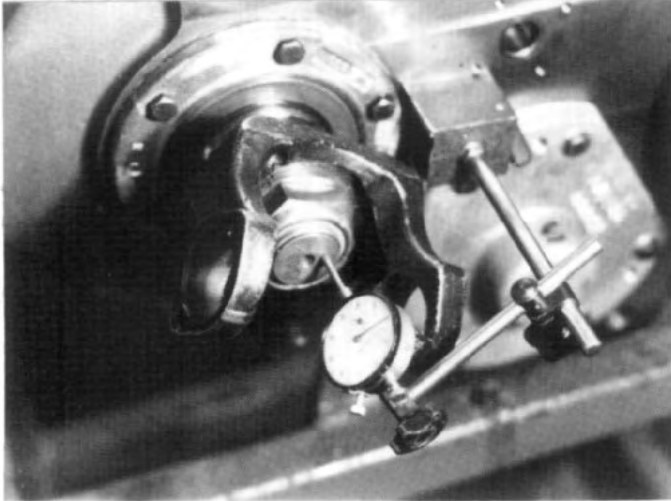

FIG. 6.5-1 At this point a requisite number of shims (approximately .150 inches) should have been assembled under the relative cap, carrier or declutch housing, as indicated in those pertinent sections.

Mount a magnetic base dial test indicator to the housing in a suitable position near the shaft being checked, with the spindle of the dial indicator touching the end of the shaft.

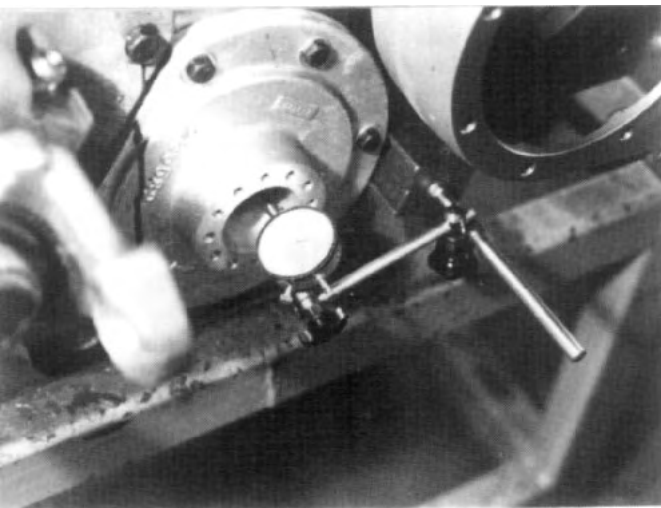

FIG. 6.5-2 Be sure dial indicator has enough length to reach the intermediate shaft through the pump carrier.

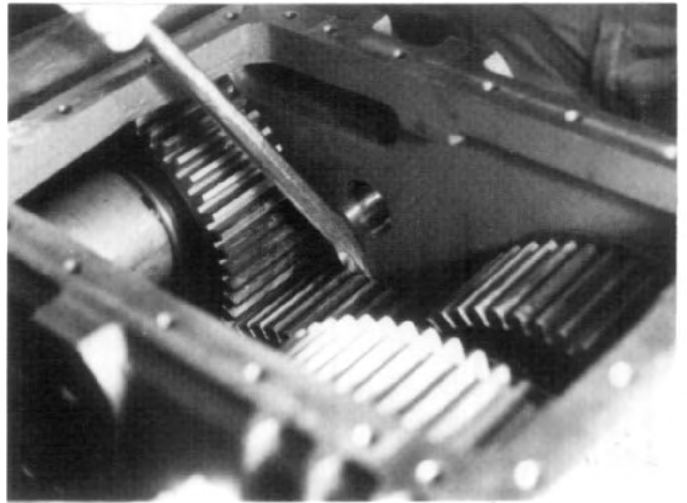

FIG. 6.5-3 With a pry bar, or other suitable tool, between the respective gear and the housing wall, use a moderate amount of hand pressure to move the shaft assembly in each direction while reading the dial indicator. Be sure the shaft is moving and not just the gear on the shaft. Vary the number of shims to provide the correct end float. All bearings on the TC-142 must have between .003 and .008 inches of end float.

NOTES

6.6 SHIFT SHAFT ASSEMBLY AND ADJUSTMENT



FIG. 6.6-1 Assemble shift shaft with small O-ring, adapter tube with O-rings, spring, stop ring, piston with O-ring, lockwasher and locknut together as shown.

NOTE: Do not forget small O-ring on .375 diameter threaded portion of shaft.

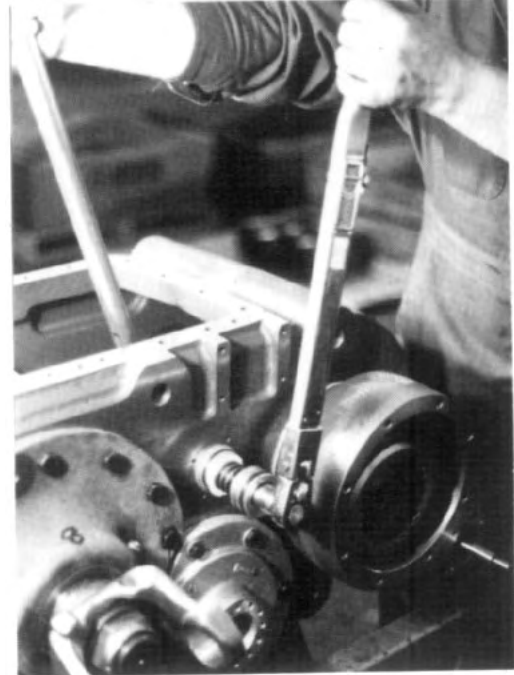

FIG. 6.6-3 Temporarily tighten hexagon locknut on shaft and while restraining locked nut, tighten locknut retaining piston to appropriate torque. Loosen shift fork locking nut.

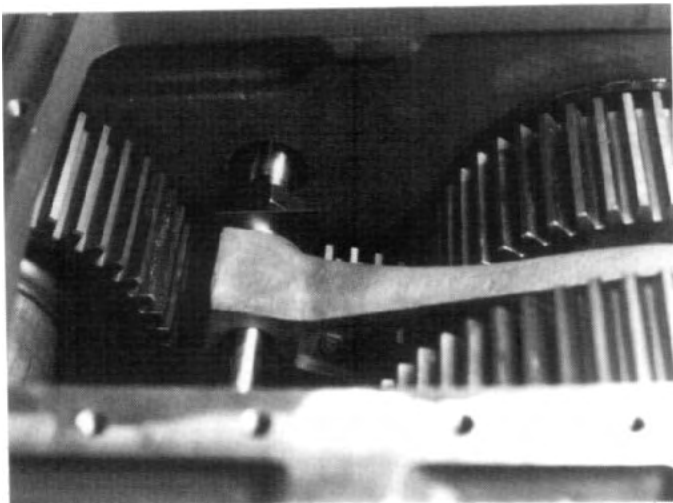

FIG. 6.6-2 Slide shaft assembly into housing and into hexagon nut, lockwasher, and shift fork. Nut and lockwasher may be placed on either side of shift fork. Shift fork must be in groove of clutch collar.



FIG. 6.6-4 Apply a liberal smear of oil and grease slurry to O-ring areas of adapter tube and piston. Presoak the piston felt seal in 30W oil overnight, and wrap into wide groove of piston. While retaining felt in groove with fingers push the cylinder tube onto the piston with the hands. Use caution not to pinch the O-ring seals.

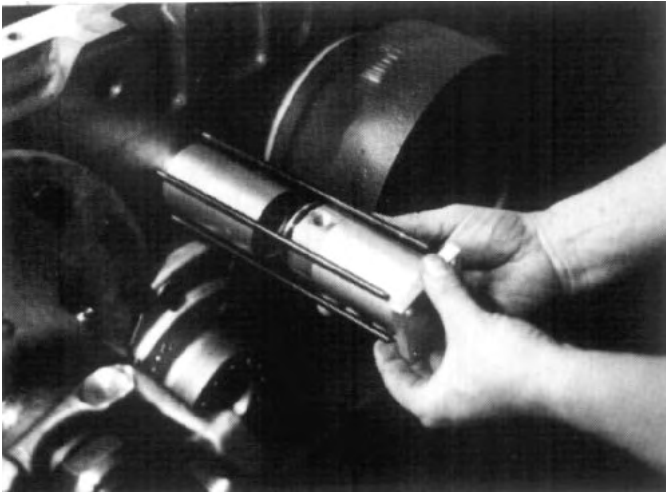

FIG. 6.6-5 If transfer case is not fitted with a neutral shift add the end cap and cap screws at this point, tighten to appropriate torque. Be sure to tighten cap screws evenly. If transfer case has neutral capability, add the long studs and slide the neutral adapter tube with cylinder tube attached into the range shift cylinder. Add stop ring and neutral piston and shift shaft assembly to cylinder. Add end cap with O-ring and tighten nuts on studs evenly to appropriate torque.

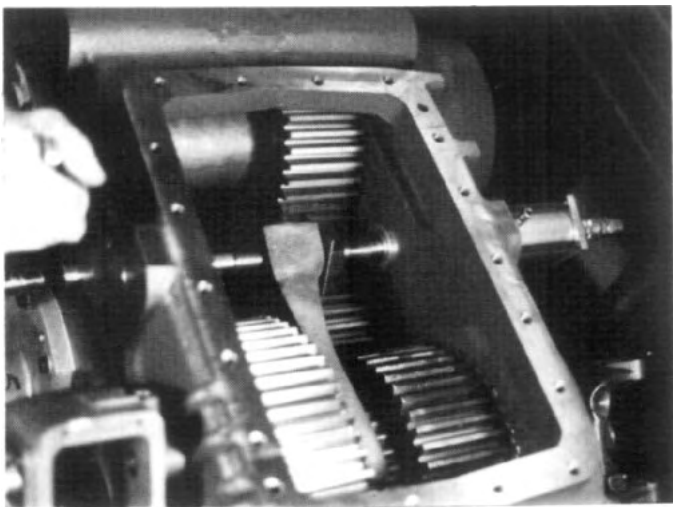

FIG. 6.6-6 Connect 100 psi air line to neutral shift cylinder and allow fork to shift into neutral. With hexagon key in end of shaft, turn shaft to move shift fork and clutch collar in relation to gears.

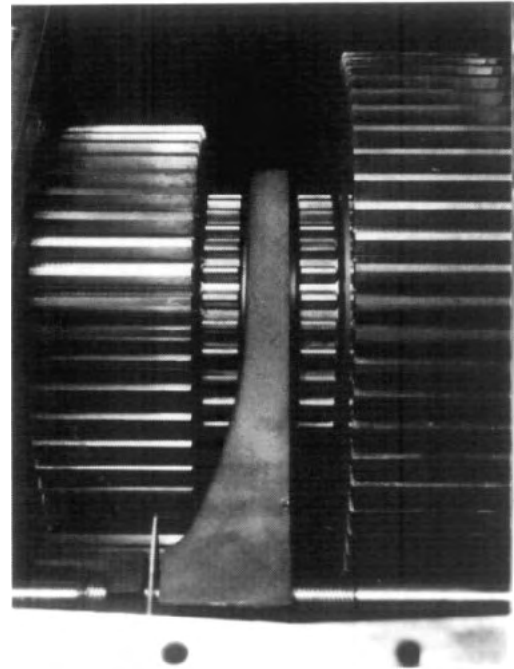

FIG. 6.6-7 On cases with neutral shift cylinder, adjust shift fork to position clutch collar evenly between the direct and underdrive gears on the lower shaft. Remove air from neutral cylinders and apply to other cylinder port. Clutch should shift from direct to underdrive range as the air is applied, and spring return when air is removed. On the TC-142 without neutral shift cylinder, adjust for equal distance between clutch collar and underdrive and direct drive gears with air applied and released.

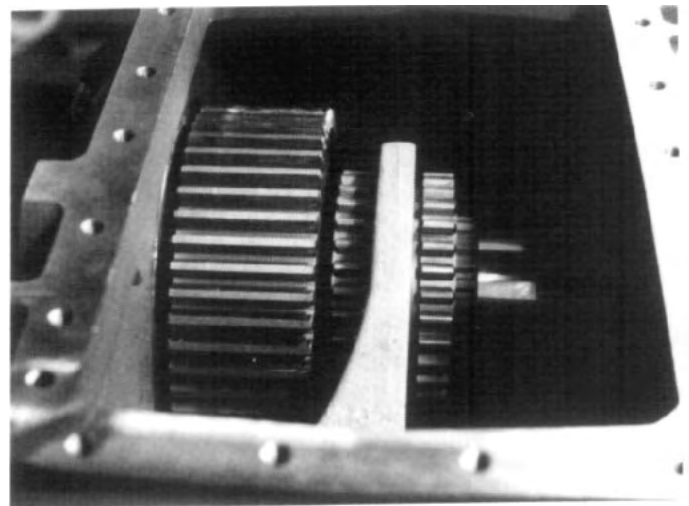

FIG. 6.6-8 On the TC-1421 remove air from shift cylinder and allow clutch to engage high range. Adjust shift shaft with hexagon key slightly out of engagement until free play can be felt between the shift fork and clutch collar. Shift clutch collar out of engagement to be sure teeth are clearing gear in neutral position.



FIG. 6.6-9 With open end wrench tighten nut on shift shaft to the appropriate torque while holding the hexagon key in the end of shift shaft.

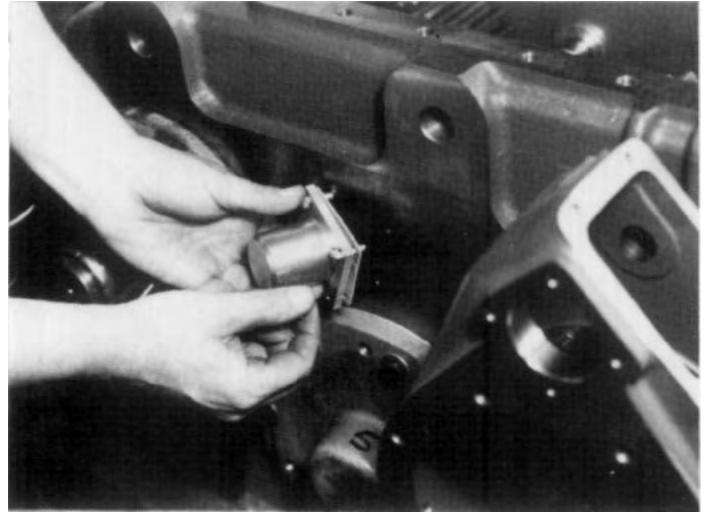

FIG. 6.6-11 Assemble end cap with gasket to housing and tighten cap screws to the appropriate torque.

NOTES

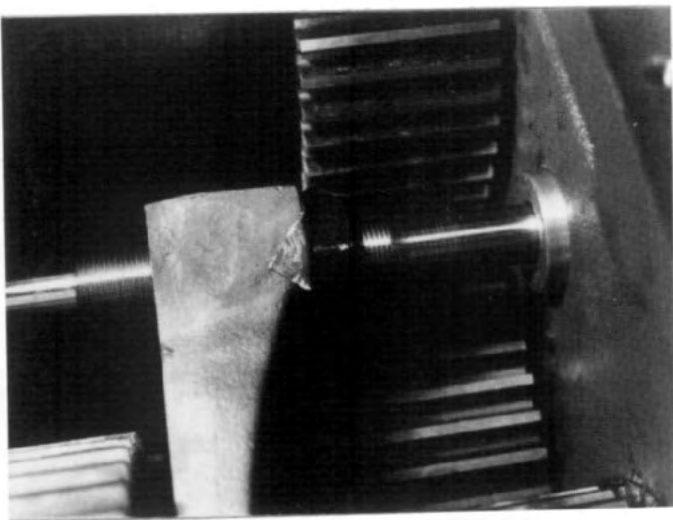

FIG. 6.6-10 Bend lockwasher corner over one flat of hexagon nut and another corner over a suitable portion of the shift fork to prevent the nut from loosening.

6.7 FRONT DRIVE AND PTO DECLUTCH ASSEMBLY

Make sure all parts are clean, dry and free from lint. All traces of storage wax or paper should be removed. Leave bearings in wrapper until ready to use. Do not handle any more than is absolutely necessary. Examine all parts for wear or damage, discard and replace where necessary.



FIG. 6.7-1 Press bearing cups into carrier with suitable press.



FIG. 6.7-2 Place output shaft bearing cones in heater for approximately 3 minutes. While waiting assemble snap ring and clutch gear to output shaft. Wearing heat resistant gloves assemble bearing cone to output shaft, add spacer ring between cones and lower carrier with cups onto shaft. Add second bearing cone to shaft, turn carrier to be sure it is free.



FIG. 6.7-3 Add blanking sleeve or yoke, washer and locknut to output shaft and tighten nut. Mount magnetic base dial test indicator to flange of carrier and check for bearing float on end of shaft as indicated in End Float Adjustment section. End float should be between .003 and .008 inches. Spacer between bearing cones must be machined or changed to one of suitable dimensions to provide the correct end float dimension.

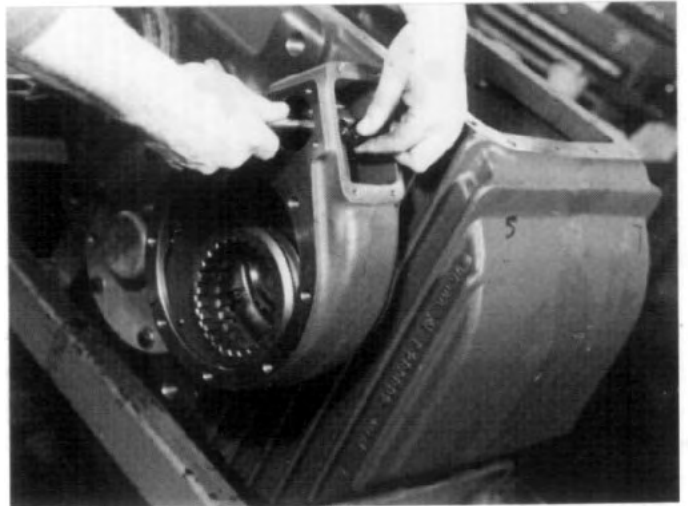

FIG. 6.7-4 If not already mounted, assemble declutch housing to transfer case housing. If not already completed, transfer case shaft end float must be adjusted at this point. Assemble shift fork in clutch collar groove and place in declutch housing. Slide shift shaft into shift fork and add pinch bolts.

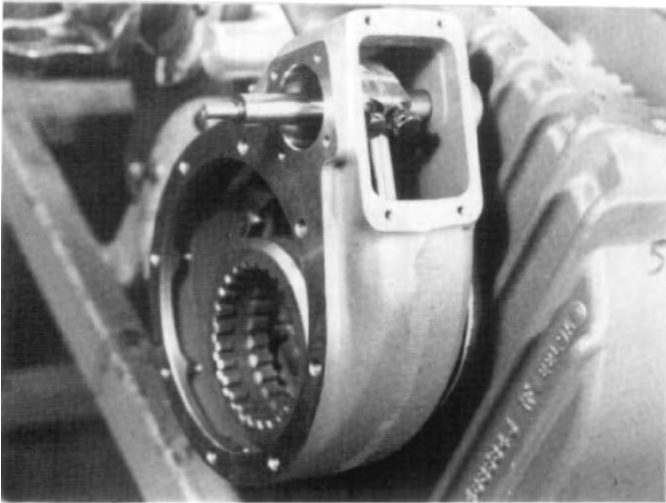

FIG. 6.7-5 Note direction of fork and pinch bolts in opening. Add small O-ring to shift shaft.

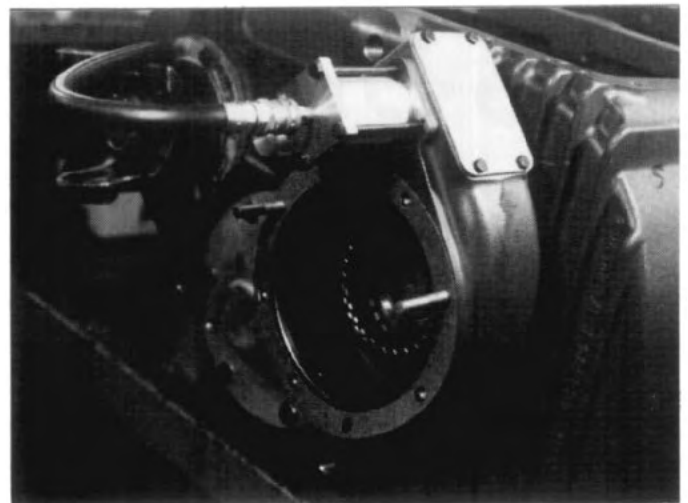

FIG. 6.7-8 Apply air to shift cylinder and engage clutch collar with clutch gear on transfer case shaft.

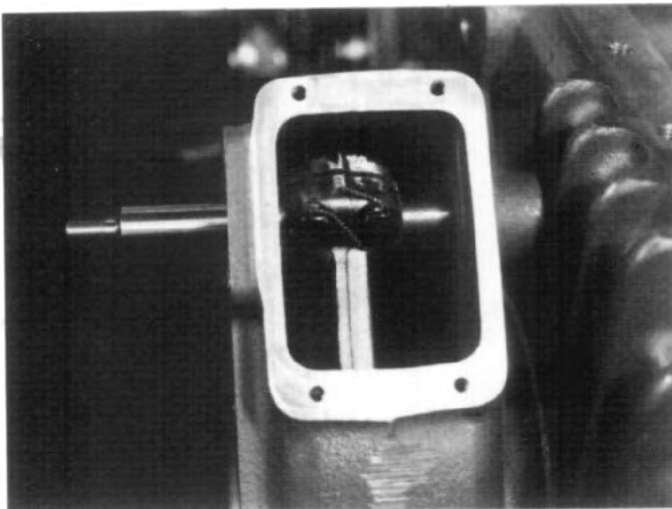

FIG. 6.7-6 Tighten pinch bolts to appropriate torque and safety lockwire as shown.



FIG. 6.7-9 With air applied to shift cylinder, align clutch gear on declutch output shaft with internal gear teeth on clutch collar and assemble carrier with gasket to the opening of the declutch housing. Tighten 8 mounting bolts to the appropriate torque.



FIG. 6.7-7 Assemble shift components as shown and indicated in shift shaft assembly section. Add cover plate.

6.8 LUBRICATION PUMP AND PLUMBING ASSEMBLY

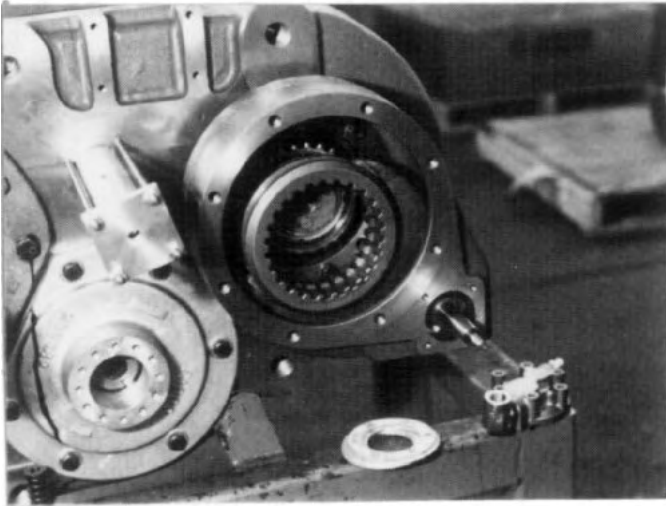

FIG. 6.8-1 The lubricating pump mounts on the end of the intermediate shaft and is driven by a pump tang engaging a slot on the end of the shaft.

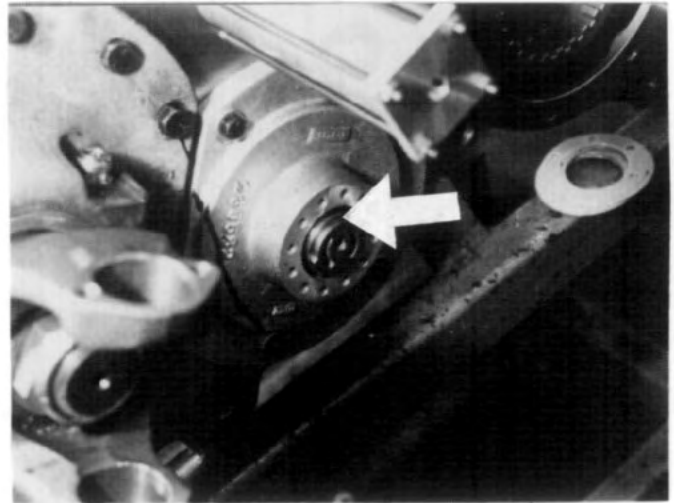

FIG. 6.8-3 Assemble pump components back together on end of shaft. Turn shaft so that shoulder recess (arrow) on end of pump is in upper position.

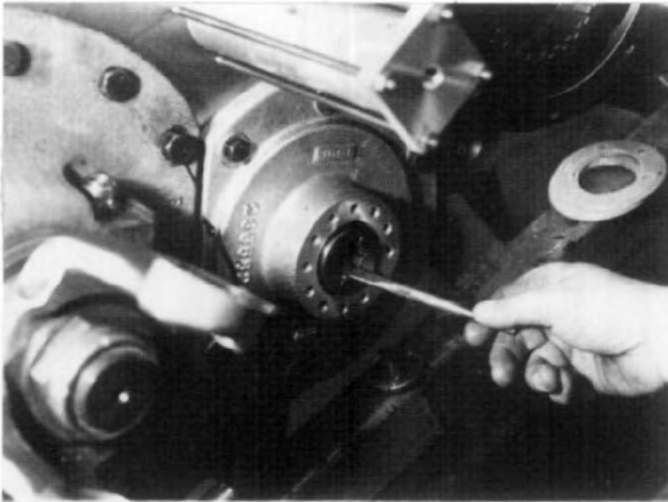

FIG. 6.8-2 Disassemble pump and place spring in hole of intermediate shaft with ferrule at bottom, and mount pump sleeve on intermediate shaft being sure that drive tang engages the slot in end of shaft. Smear all components liberally with grease oil slurry, especially the rotor and chamber.



FIG. 6.8-4 Assemble pump end cap with 2 cap screws, just started, to carrier. NOTE - Be sure pin (arrow) on flat mating face of cap engages shoulder slot on end of pump. Turn pump assembly if necessary to place cap in correct orientation for plumbing.



FIG. 6.8-5 Press pump end cap lightly until contact with spring, but not compression, is felt. With pack of shims measure space between cap and carrier. Remove five (5) shims from number of shims counted and assemble under cap. Once again noting that pin correctly engages shoulder slot. Leave at least 1 shim in pump assembly.

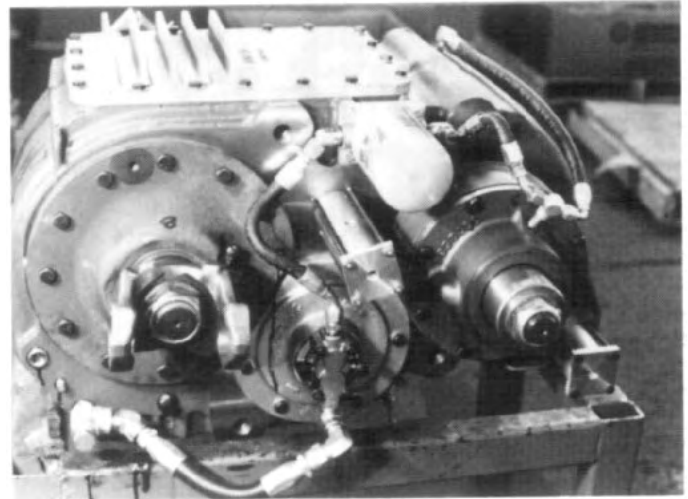

FIG. 6.8-7 Connect hoses as shown. NOTE - Replace filter unit if it has been in service. Be sure suction strainer in bottom fitting is clean. Be sure connections to pump match direction arrow on cap indicator for oil flow.

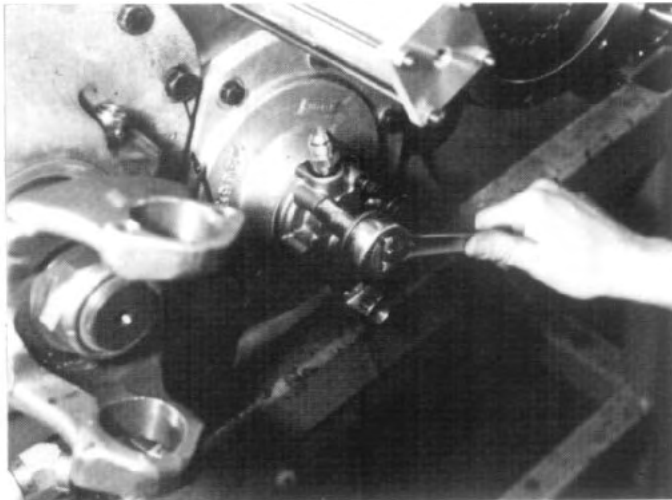
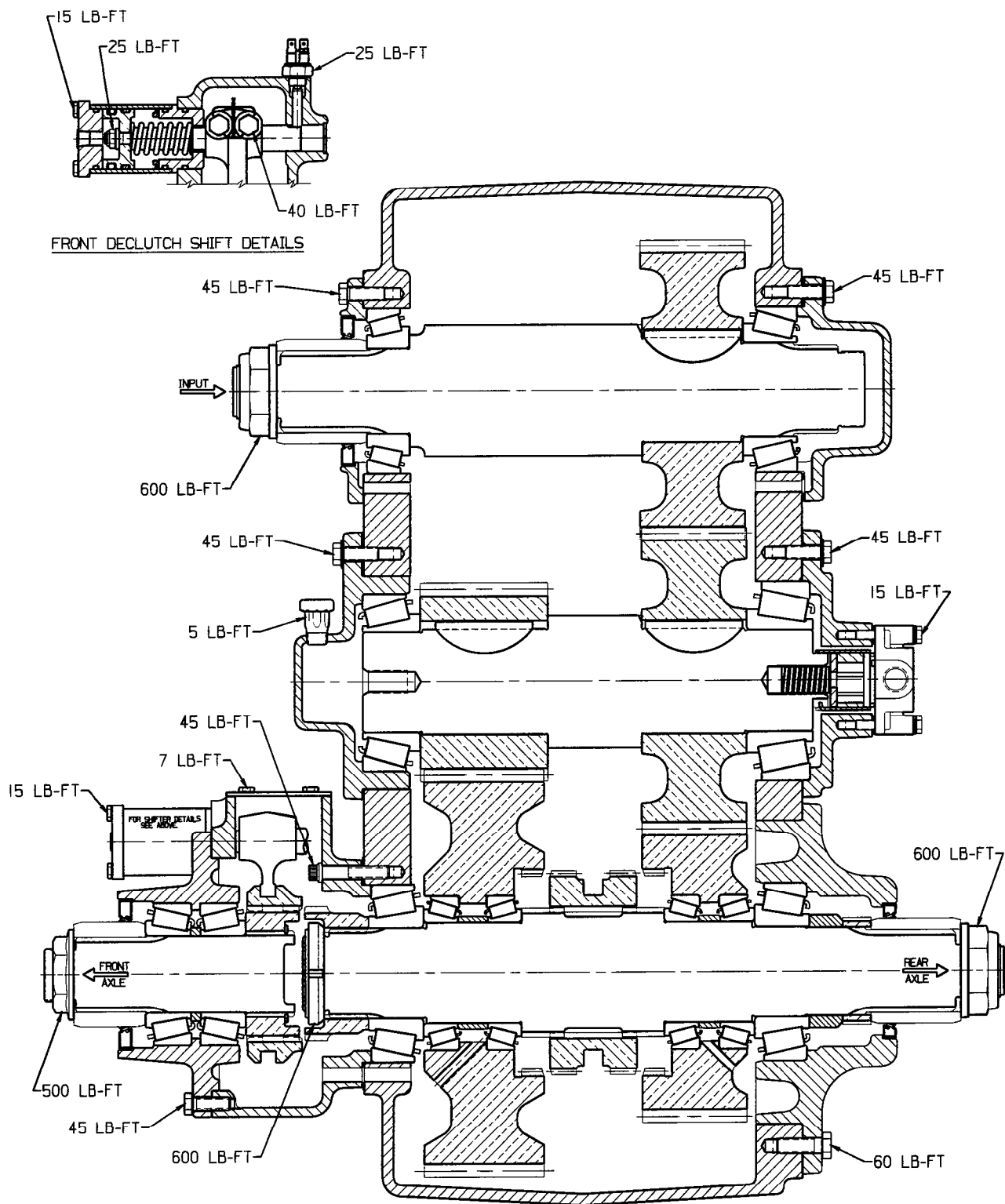

FIG. 6.8-6 Tighten cap screws to appropriate torque.

The case is now ready for reinstallation in vehicle. When case is mounted connect air and electrical lines and fill with oil to the bottom of the oil filler plug hole.

7.0 TORQUE SPECIFICATION



ALL TORQUE VALUES ARE FOR DRY NON-LUBRICATED THREADS,
AND SHOULD BE WITHIN 10% OF VALUES SHOWN.

FABCO TC-142/TC-1421 TRANSFER CASE

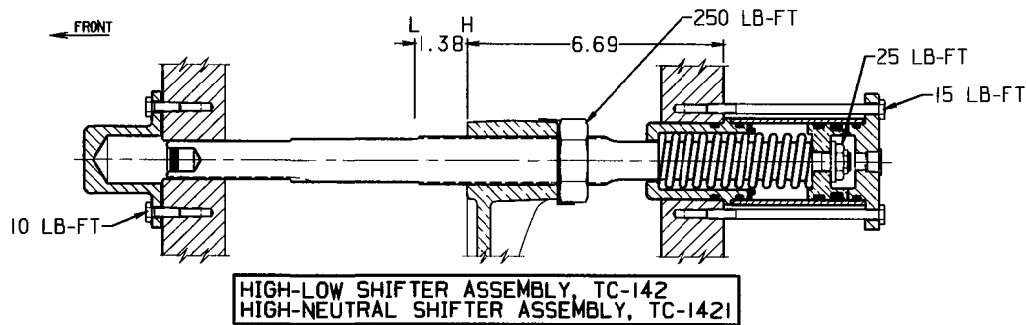
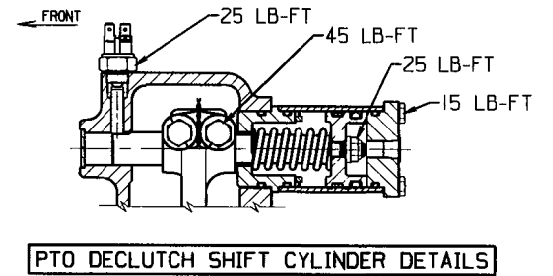
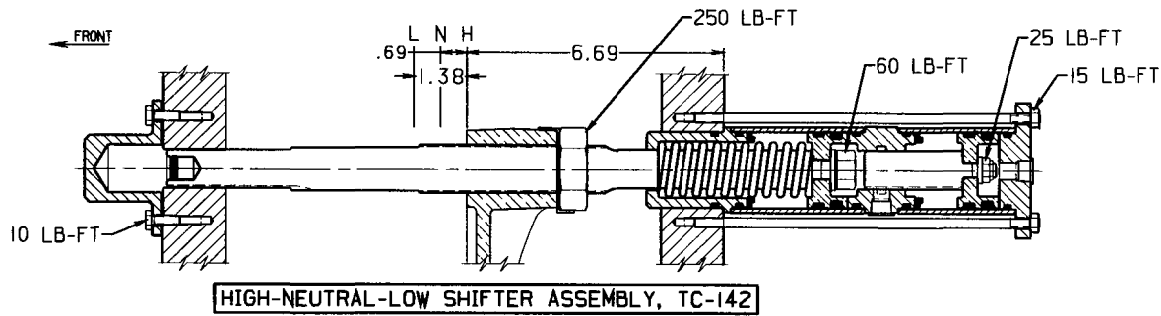
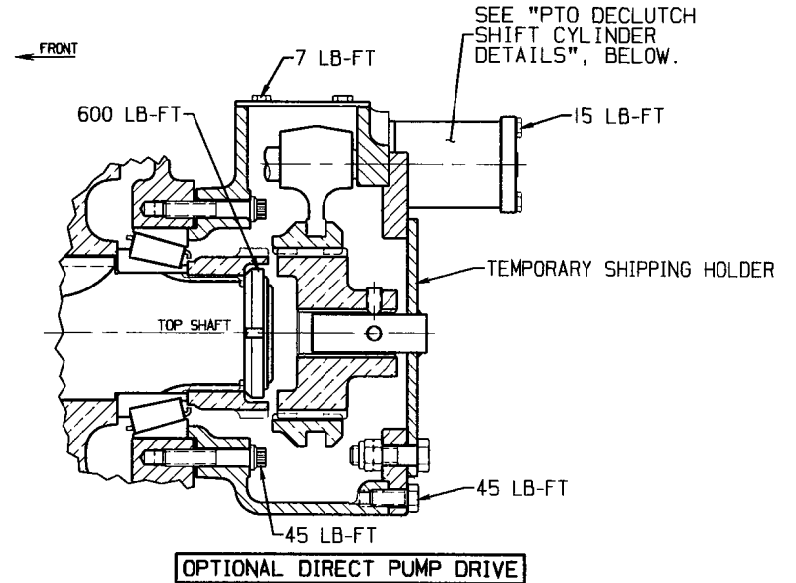
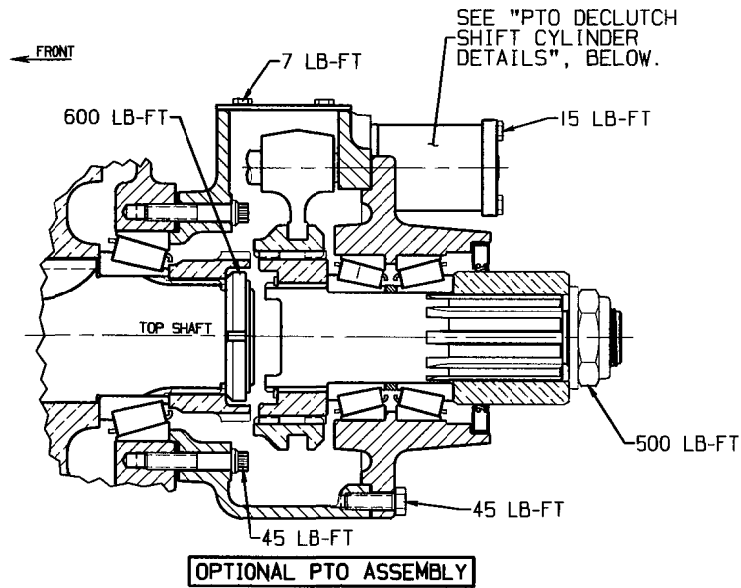

OIL FILTER:
OIL GASKET AND
TIGHTEN 3/4 TURN
AFTER GASKET
CONTACTS BASE.

15 LB-FT

45 LB-FT

15 LB-FT

OIL LEVEL PLUG
50 LB-FT

25 LB-FT

MAGNETIC DRAIN PLUG
50 LB-FT

REAR VIEW

10.0 TOOLING

Details of tooling to facilitate servicing the TC-142/1421 Transfer Case.

Service tools may be manufactured to these drawings or, Fabco Automotive may be contacted for a price and delivery quotation.

The manufacture of these tools should be carried out by professional machinists and certified welders, following typical good workmanship procedures and safe practices.

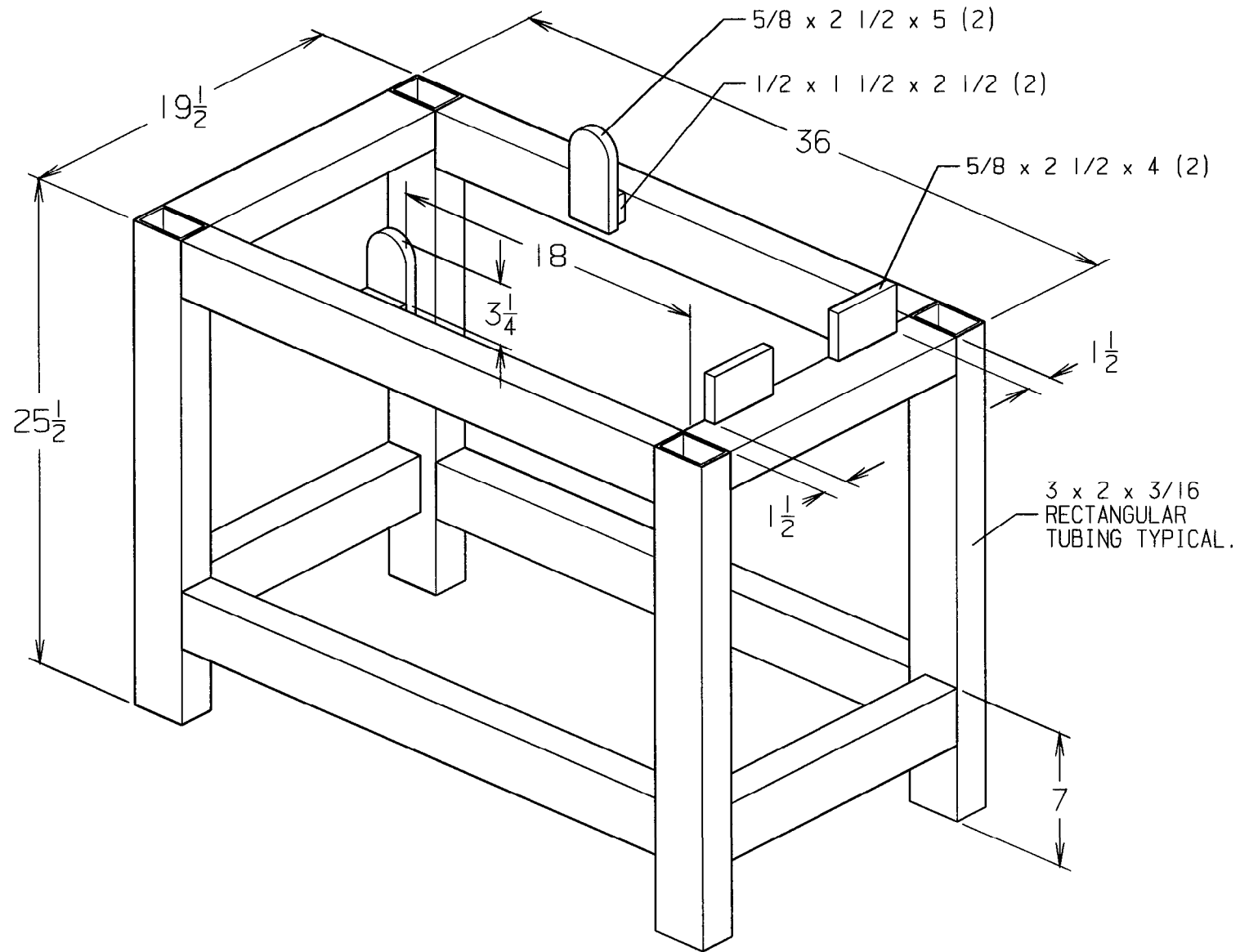

SUGGESTED DESIGN FOR WORKSTAND

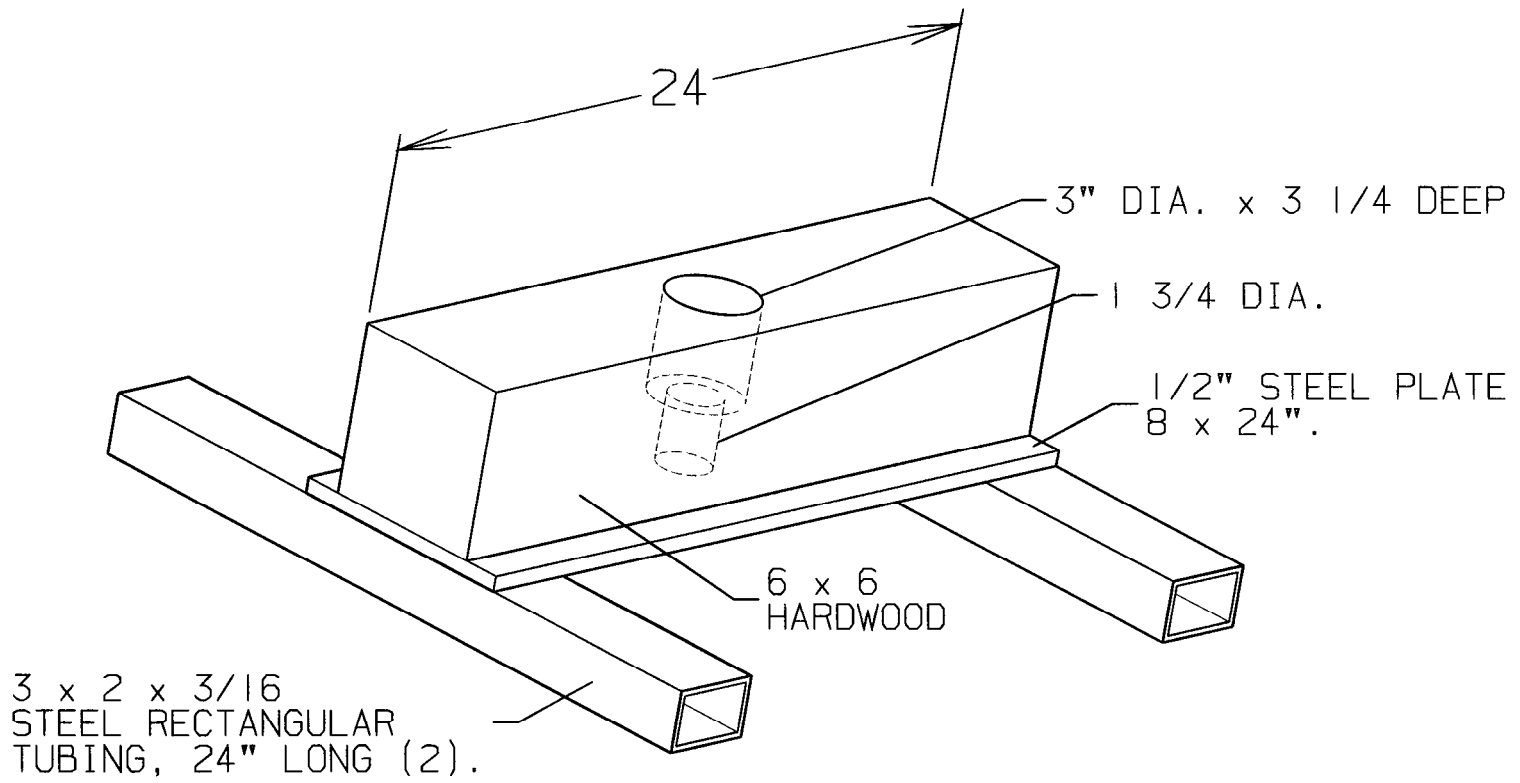

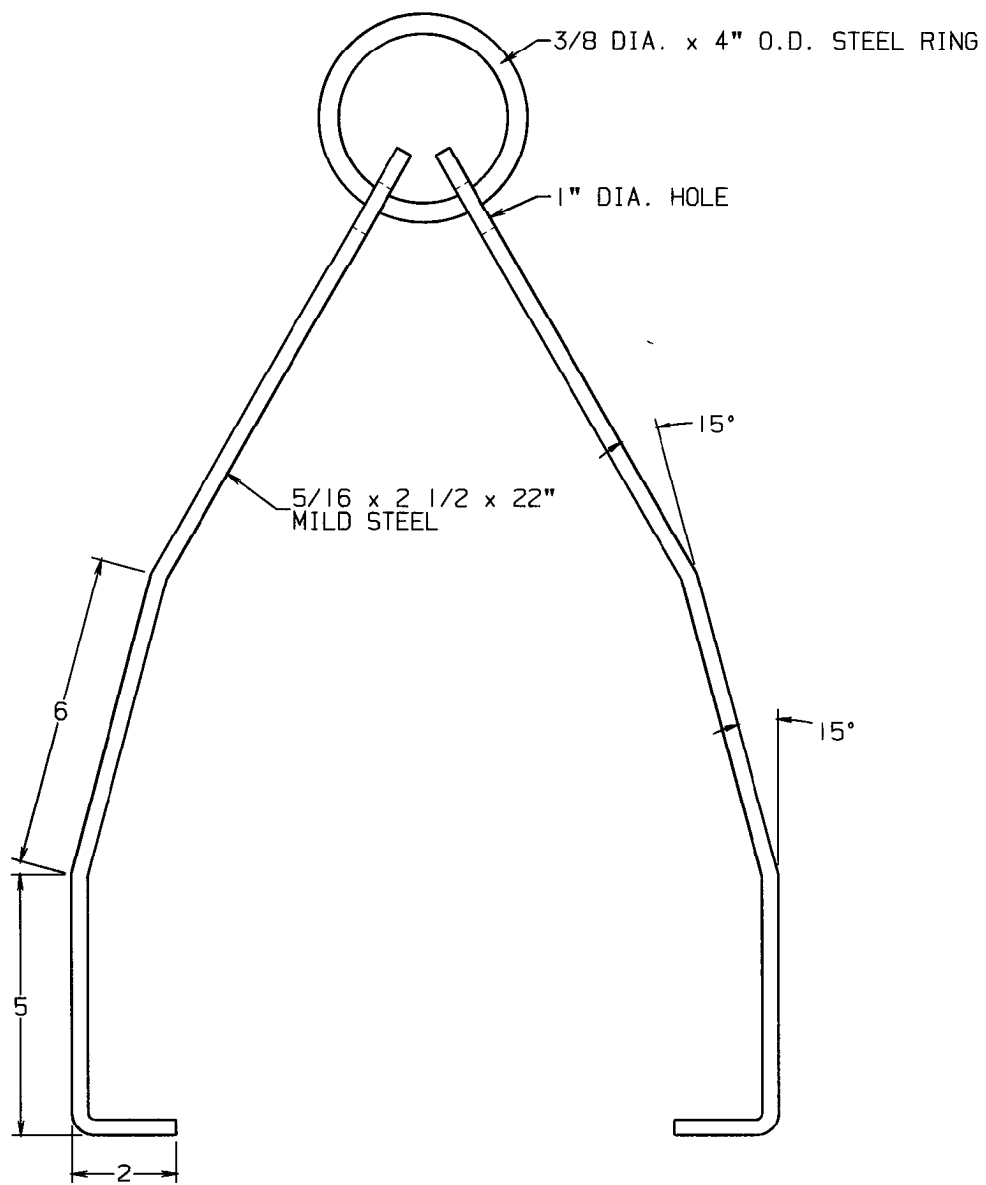

866-0648 - UNDERDRIVE GEAR HOOK

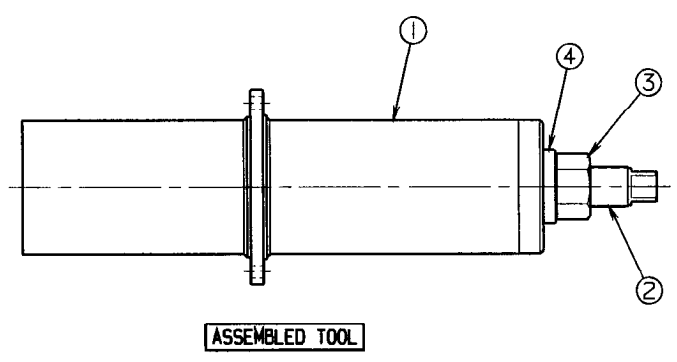
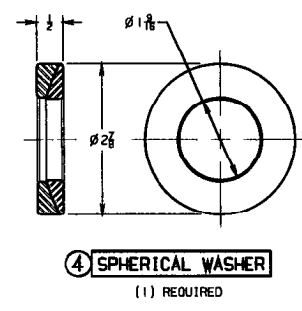
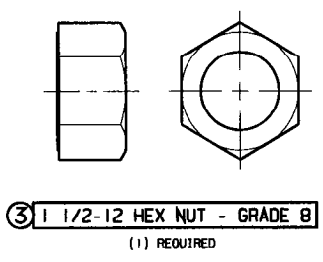
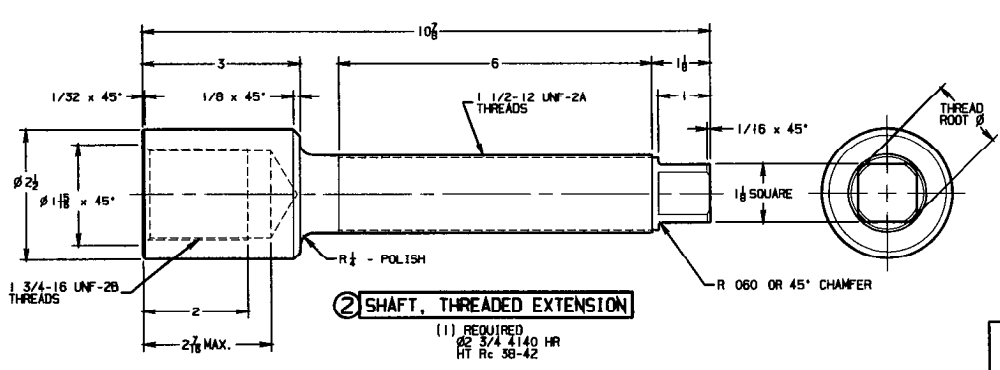
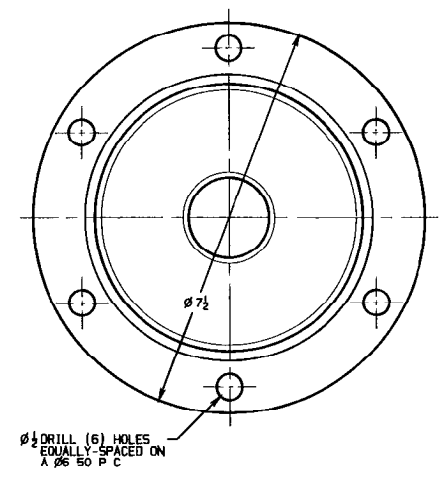
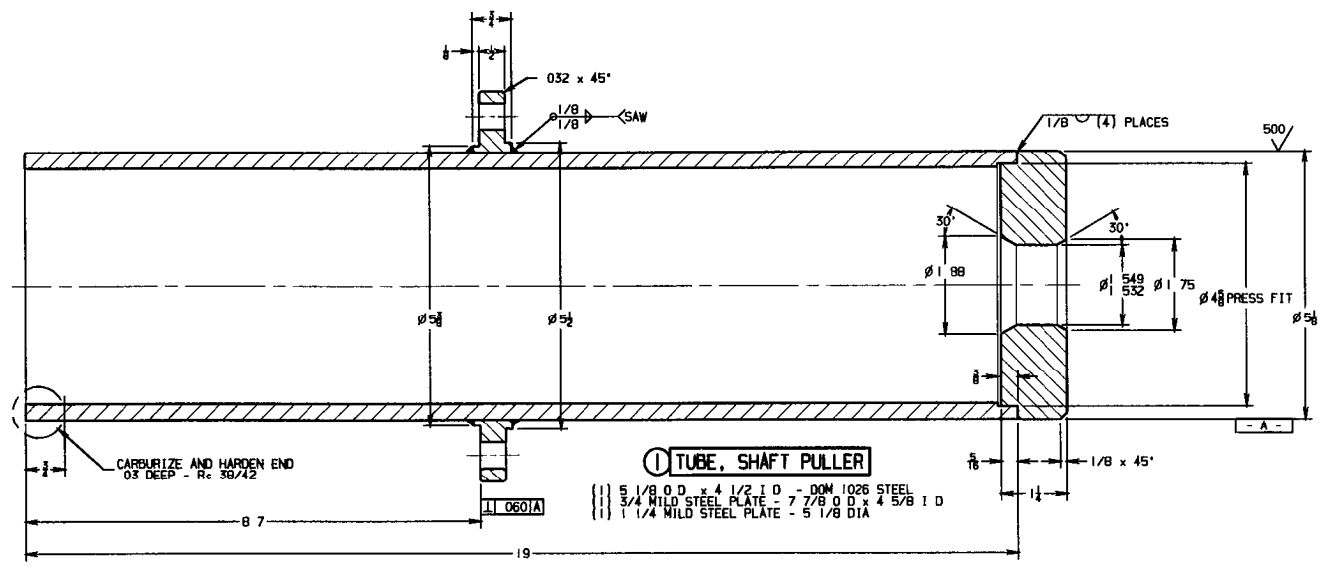

SECT. 10 PG. 4

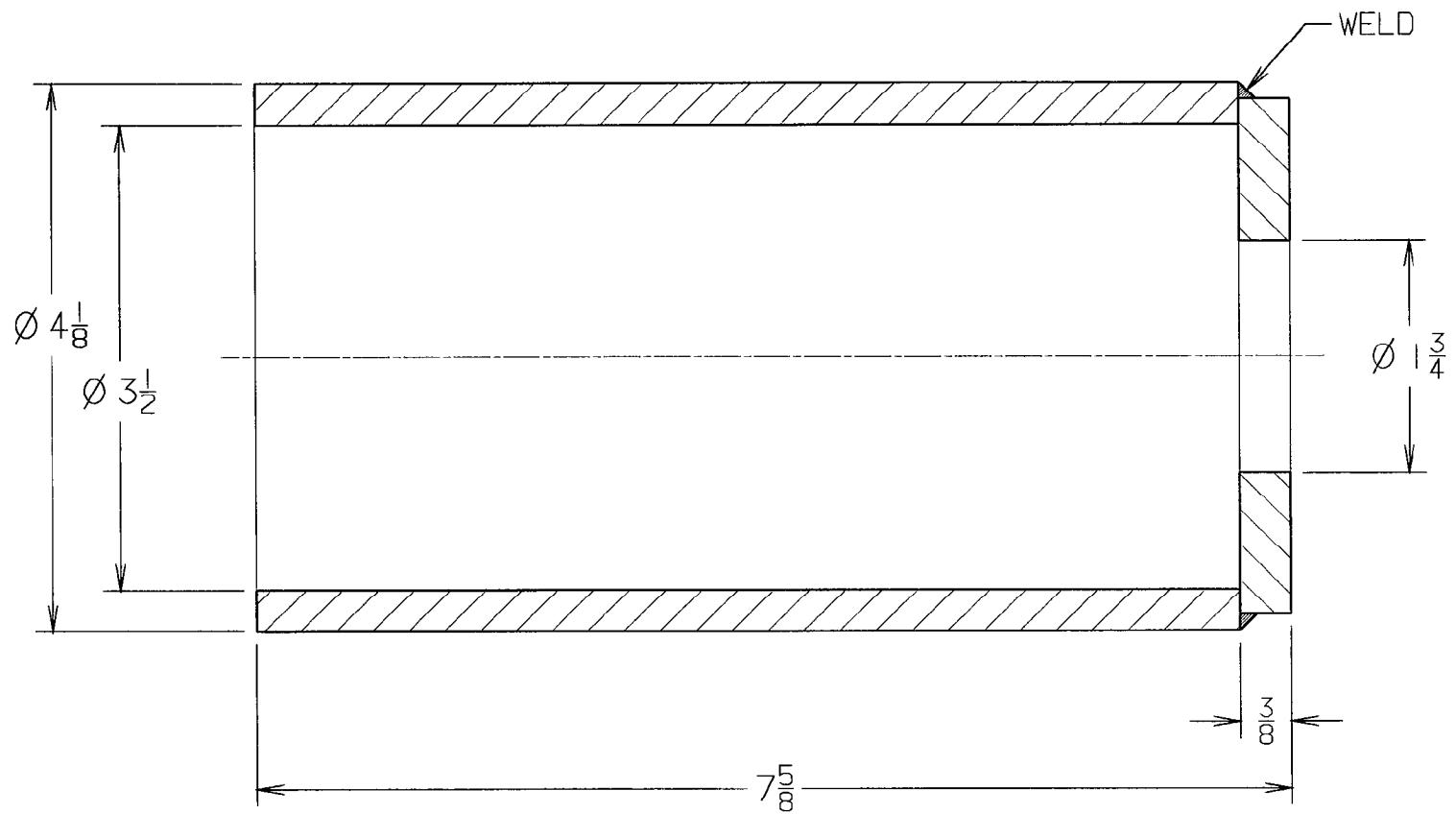

866-0649 - DIRECT DRIVE PUSHER

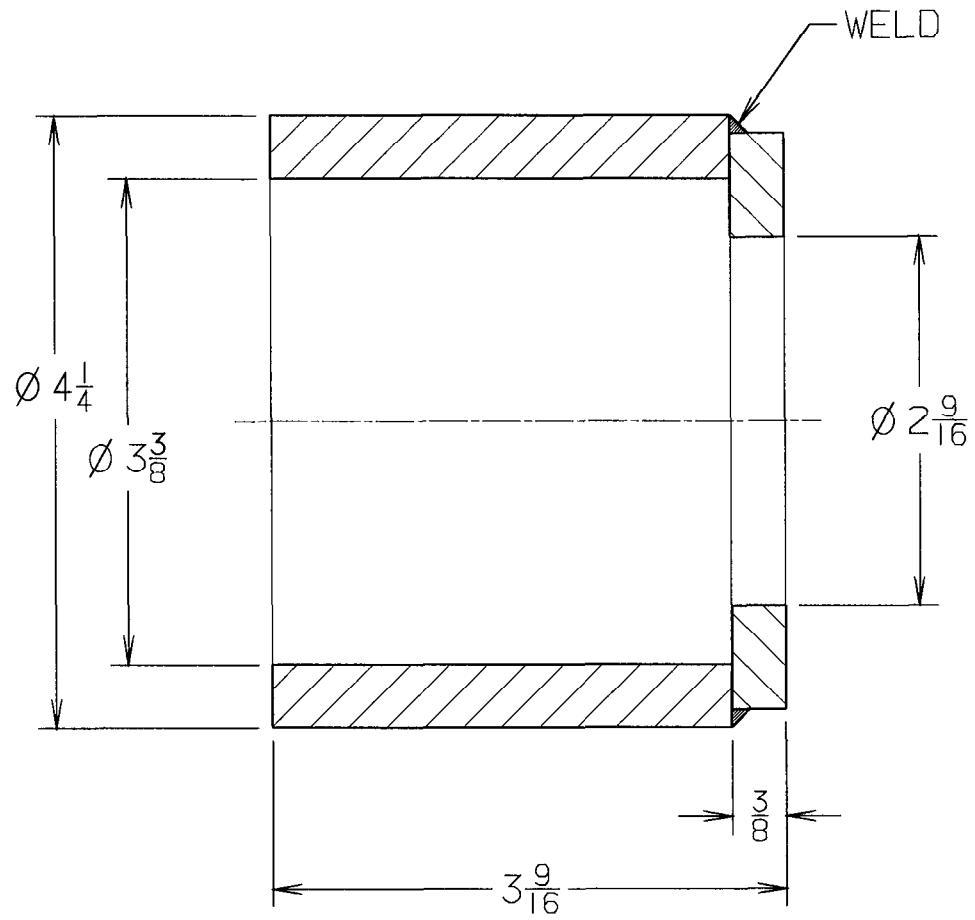

866-0650 - UNDERDRIVE PUSHER

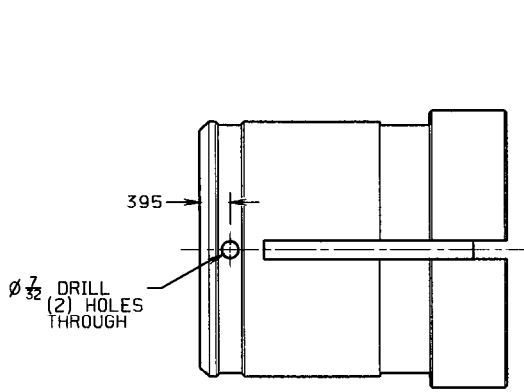

WRENCH BODY
4140 - HARDEN TO Rc 40-45

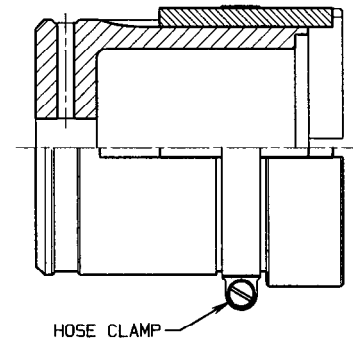
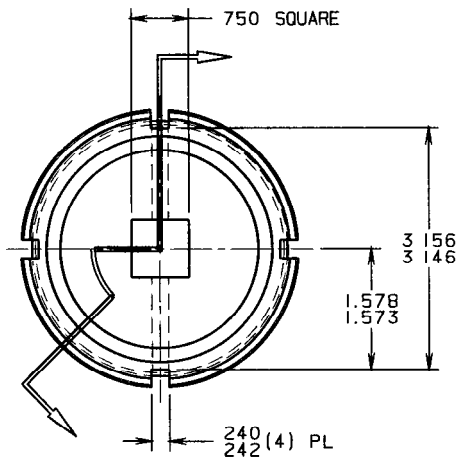

ASSEMBLED WRENCH

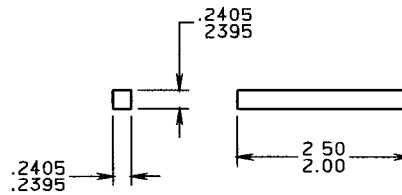
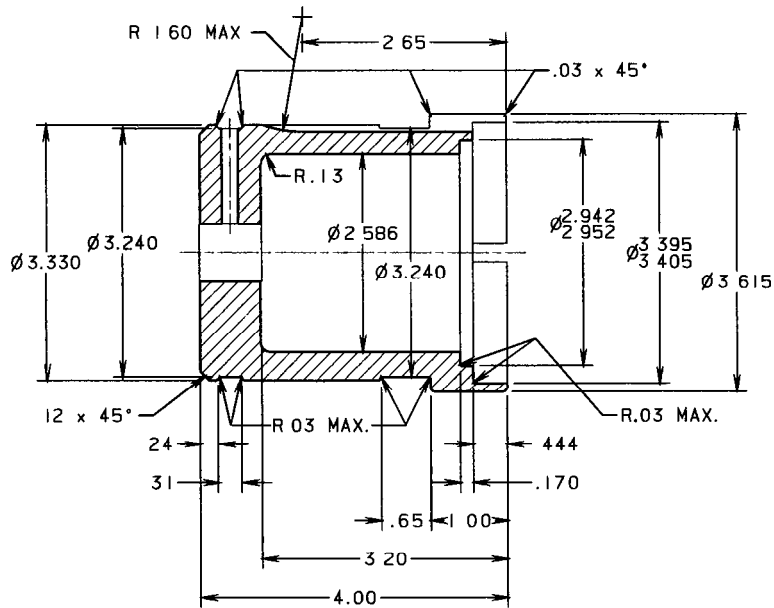

WRENCH KEY
(4) REQUIRED - MAKE FROM 1/4" SQUARE CUTTING TOOL